

Test Equipment Catalogue

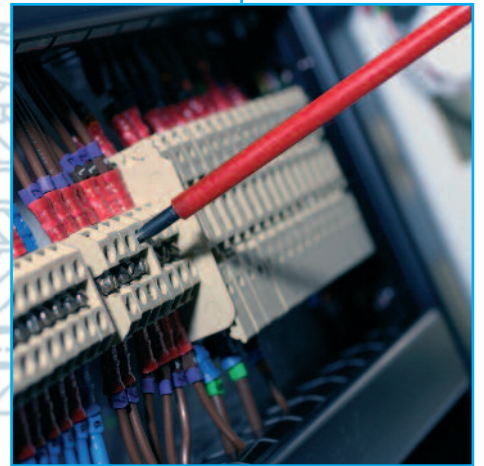
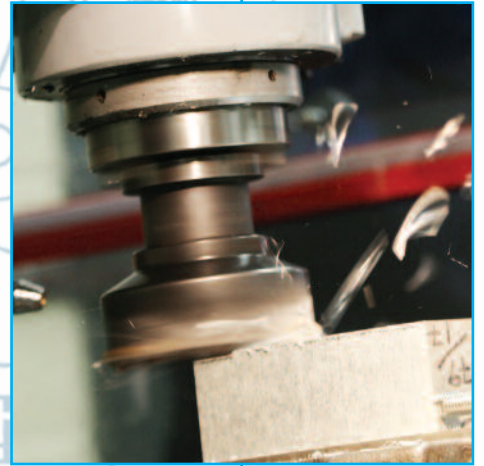

SATRA was originally formed in 1919 to provide footwear manufacturers and suppliers with technical knowledge, research and testing. Since those early years, SATRA has developed significantly to become the world's leading research and technology centre of its kind. We now employ scientific, technical and support staff in the UK and China and our brand is recognised and respected in over 70 countries across a diverse spread of product sectors. SATRA is also a leading authority on international legislation and testing, and the technical aspects of a wide range of products including footwear, leather, clothing, textiles, toys, safety products, PPE, workwear, furniture and floorcoverings.

We use our technical expertise to design and build the best test equipment available. We continually research and develop new test regimes, methods and machines, including developing machines to customer-specific requirements. No other test equipment provider has such a high level of in-house technical support. SATRA test equipment is unique in having benefited from extensive user trials in SATRA laboratories.

SATRA test equipment is designed and manufactured in the UK and is supplied to a wide range of industry sectors including: leather, footwear, furniture, flooring, textiles and garments, safety products, rubber, printing and automotive, as well as to test laboratories and research institutes. We are committed to developing high quality machines and providing you with high levels of customer service and aftercare.

Most test equipment is designed for use in controlled atmospheres. Testing under controlled conditions will help ensure the reliability and consistency of the test results. The preferred conditions for testing footwear and most materials are $23 \pm 2^{\circ}\text{C}$ and $50 \pm 4\%$ rh. Other conditions are permissible however, depending on the test method used. Temperature control is essential for all testing, humidity control is not essential for small quality control laboratories unless specialised testing is performed.

Alphabetical Index

ABRASION – BIOMECHANICAL	STM 528	1
ABRASION – LACES	STM 152 / STM 439	2
ABRASION – SATRA/MARTINDALE	STM 633	2
ABRASION – MOTORCYCLE	STM 504	3
ABRASION – SOLING	STM 140 / STM 602	3
ADHESION – CREEP	STM 164	4
ADHESION – FINISH	STD 112	4
ADHESION – LABORATORY JOINT PRESS	STM 124	4
ADHESION – SOLE	STD 185	5
COLOUR FASTNESS	STD 442 / STD 461 GC / STD 461 GS / STD 488	5
	STD 422	6
COMPRESSION SET	STD 133 / STD 401	6
COMPRESSION - HOSIERY	STM 579	7
COMPRESSION – REPEATED	STM 512	7
CONDUCTIVITY SIMPLE CONDUCTIVITY	STD 464	7
CONDUCTIVITY	STD 470	8
CONTACT HEAT	STM 531	8
CUT RESISTANCE	STM 611 / STM 610	8
FITTING	STD 206 / STD 225 / STD 224	9
	STD 219 / STD 223	10
FLEXING – FIBREBOARD	STM 129	10
FLEXING – MIDSOLE	STM 441	10
FLEXING – SOLING	STM 141 / STD 405 / STM 612	11
FLEXING – UPPER	STM 601 / STM 701	12
FLEXING – WHOLE SHOE	STM 184	12
FLEXING – WHOLE SOLE	STM 465	12
GLOVE TESTING (EN 388)	STM 633 / STM 611 / STM 610 / STM 566	13
HARDNESS (DUROMETERS)	STD 226 / STD 227	14
HEAT RESISTANCE	STM 455	15
HUMIDITY – SENSOR	STD 228	15
IMPACT – HEELS	STD 155 / STM 156	16
IMPACT – SAFETY FOOTWEAR	STD 609	17
INSULATION – SAFETY FOOTWEAR	STM 471 / STM 472	18

Alphabetical Index continued

LASTOMETERS	STM 463	18
	STD 104 / STD 190 / STD 190L	19
LEATHER ANALYSIS	STM 145	19
LEATHER ASSESSMENT	STD 114 / STD 119	20
LIGHT CABINET	STM 500	20
LOW TEMPERATURE TESTING	STM 101F / STM 408F / STM 477F / STM 141F /	21
	STM 612F / STM 465F	21
MOISTURE MANAGEMENT	STM 567	22
MOLTEN METAL – SPLASH	STM 524	23
OZONE CHAMBERS	HTE 703 / HTE 903	24
PERMEABILITY	STM 175 / STM 473 / STD 478	25
PINCH AND GRIP	STD 620 / STD 621	26
PIPINESS	STD 174	27
PLASTIMETER	STD 449	27
RESILIENCE	STD 645	27
RUB FASTNESS	STM 643B / STM 421 / STM 461	28
	STM 462	29
SHOCK ABSORPTION – DYNAMIC	STM 479	29
SLIP RESISTANCE	STM 603	30
STATE OF CURE	STM 135	31
STIFFNESS	STM 507	31
TENSILE TESTING (MANUAL)	STD 172	31
TENSILE TESTING	STM 566 / STM 766	32 - 33
THERMAL – RESISTANCE	STM 511	34
THERMAL – WHOLE SHOE	STM 567	34
THICKNESS	STD 483 / STD 484 / STD 495	35
TOE PUFFS AND STIFFENERS	STD 153	35 - 36
VACUUM FORMING	STM 329	36
	STM 330	37
WATER RESISTANCE	STM 505 / STM 606D	37
	STM 703 / STD 704 / STM 706	38
ZIPS	STM 590	38

Numerical Index

STM 101F	Low Temperature Vamp Flexing Machine – 12 Station	21
STD 104	Hand Operated Lastometer	19
STD 112	Adhesion of Finish Tester	4
STD 114	Leather Shrinkage Apparatus	20
STD 119	Wrinkleometer	20
STM 124	Laboratory Press for Adhesive Joints	4
STM 129	Fibreboard Flexing Machine	10
STD 133	Compression Set – Constant Stress	6
STM 135	State of Cure Tester	31
STM 140	Soling Abrasion Tester	3
STM 141	Ross Flexing Machine	11
STM 141F	Low Temperature Ross Flexing Machine	21
STM 145	Shaking Machine for Leather Analysis	19
STM 152	Shoelace Abrasion Tester – Lace to Eyelet Method	2
STD 153	Compression Cage used in Toe Puff Analysis	35
STD 153/C	Repeated Dome Collapsing Device	36
STD 153/D	Toe Puff Dome Forming Device	35
STD 153/H	Dome Height Measuring Equipment	35
STD 153/HD	Dome Height Measuring Device	35
STD 153/P	Press for Forming Toe Puff Domes	35
STD 155	Heel Impact Tester	16
STM 156	Heel Fatigue Tester	16
STM 164	Creep Cabinet for Adhesion Testing	4
STD 172	Simple Tensile Tester	31
STD 174	Break / Pipiness Scale	27
STM 175	Permeability / Absorption Machine	25
STM 184	Whole Shoe Flexing Machine – Wet and dry	12
STM 184H	Whole Shoe Flexing Machine – High leg	12
STD 185	Sole Adhesion Tester	5
STD 190	Instant Lastometer	19
STD 190L	Instant Lastometer (extended throat)	19
STD 206	Quarter and Back Height Gauge	9
STD 219	Shoe Measuring Callipers – Size Stick	10

Numerical Index continued

STD 223	Digital Last Assessment Jig	10
STD 224	SATRA Shoe Fitting Boards	9
STD 225	Internal Shoe Size Gauge	9
STD 226	Digital Durometer	14
STD 227	Analogue Durometer	14
STD 228	SATRA Sensor	15
STM 329	Vacuum Forming Machine – Hand operated	36
STM 330	Vacuum Forming Machine – Motor operated	37
STD 401	Compression Set – Constant Strain	6
STD 405	Chisel Holding Jig for use with Ross Flexer	11
STM 408F	Low Temperature Bally Flexing Machine – 8 station	21
STM 421	SATRA Rub Fastness Tester – Single station	28
STD 422	Crockmeter	6
STM 439	Shoelace Abrasion Tester – Lace to Lace method	2
STM 441	Midsole Flexing Device	10
STD 442	Perspirometer – for Perspiration Fastness test	5
STD 449	Low Profile Plastimeter	27
STM 455	Heat Resistance Tester	15
STM 461	Circular Rub Fastness Tester	28
STD 461GC	Grey Scales	5
STD 461GS	Grey Scales	5
STM 462	Circular Rub Fastness Tester – Automatic	29
STM 463	Digital Lastometer	18
STD 464	Simple Conductivity Tester	7
STM 465	Whole Sole Flexing Machine	12
STM 465F	Low Temperature Whole Sole Flexing Machine	21
STM 470	Conductivity Tester	8
STM 471	Heat Insulation Tester – Sandbath	18
STM 472	Cold Insulation Tester	18
STM 473	Water Vapour Permeability Machine	25
STM 477F	Low Temperature Bally Flexing Machine – 12 Station	21
STD 478	Water Vapour Absorption	25
STD 479	Dynamic Shock Absorption	29

Numerical Index continued

STD 483	Leather Thickness Gauge – Deadweight	35
STD 484	Synthetic Material Thickness Gauge – Deadweight	35
STD 488	Multi Fibre Ribbon used in Water Fastness testing	5
STD 488G	Glass Plates for Water Fastness Test	5
STD 488I	Fan Assisted Oven 0–300°C	5
STD 488P	Petri Dishes for Water Fastness Test	5
STD 495	Rubber Thickness Gauge – Deadweight	35
STM 500	VeriVide Colour Assessment	20
STM 504	Motorcycle Abrasion Tester	3
STM 505	Dynamic Footwear Water Resistance Tester	37
STM 507	Dynamic Footwear Stiffness Tester	31
STM 511	Sweating Guarded Hotplate	34
STM 512	Repeated Compression Testing Machine	34
STM 524	Molten Metal Splash Tester	23
STM 528	Pedatron	1
STM 531	Contact Heat Tester	8
STM 566	Tensile Tester – PC controlled	32
STM 567	SATRA Endofoot	22
STM 579	Hosiery Compression Tester	7
STM 590	Zip Tester	38
STM 601	Vamp Flexing Machine	12
STM 602	Soling Materials Abrasion Tester	3
STM 603	Slip Resistance Tester	30
STM 606D	Water Resistance Tester for Upper Leather (Maeser type)	37
STM 609	Impact Tester for Safety Footwear	17
STM 610	Cut Resistance Evaluator	8
STM 611	Circular Blade Cut Resistance Tester	8
STM 612	SATRA/Bata Belt Flexing Machine	11
STM 612F	Low Temperature SATRA/Bata Belt Flexing Machine	21
STD 620	Glove Pinch Tester	26
STD 621	Glove Grip Tester	26
STM 633	Martindale Abrasion Tester	2
STM 643B	Rub Fastness Tester – 2 Station	28

Numerical Index continued

STD 645	Resilience Tester	27
STM 701	SATRA/Bally Flexometer – 12 station	12
STM 703	SATRA/Bally Penetrometer	38
STD 704	SATRA/Bally Stiffness Meter used with Penetrometer	38
STM 706	SATRA/Bally Permeometer	38
STM 766	Tensile Testing Machine (High Capacity)	32
HTE 703	Ozone Test Chamber	24
HTE 903	Ozone Test Chamber	24

STM 528 Pedatron



The SATRA STM 528 Pedatron was originally developed to conduct whole shoe tests, providing a realistic mechanised method of assessing soling wear. However, in addition to conducting soling wear assessments, it is also very effective in assessing a wide range of characteristics of whole footwear, including internal footwear components. The Pedatron has been developed to closely replicate the action of walking, with parameters determined from biomechanical studies of walking gaits.

The SATRA Pedatron test reproduces the flexing, shear loads, compression/impact and turning motions which occur in footwear use. The repeatable nature of Pedatron testing allows for an assessment to be made of how alternative constructions – for example, in the upper or the method of assembly – influence soling wear. The Pedatron can operate on a continuous basis producing 48,000 step cycles in 24 hours.

A standard textured flooring surface is available for footwear sole abrasion testing allowing consistent results to be obtained. In addition, a wide range of flooring surfaces can be installed in the Pedatron, and used for specific footwear to flooring interface testing.

The SATRA Pedatron has been found to be very effective, when used in conjunction with other test machines, assessing footwear over a simulated lifetime of use. For instance, a slip resistance test can be carried out on a new footwear sample using the SATRA STM 603 test machine, and then repeated after a period of Pedatron wear testing. This allows an assessment to be made of the effect of soling wear and other damage (such as compression set and/or spread) on the footwear's slip resistance. Another example is combining Pedatron wear testing with water resistance tests. Conducting a water resistance test – for example, using a SATRA STM 505 test machine before and after Pedatron testing – allows for an assessment to be made of the effects of wear on the water resistance of the footwear.

The Pedatron has also proved very effective for assessing the wear of flooring surfaces. The flooring samples are typically subjected to one million step cycles. The wear patterns created have been found to be representative of actual flooring wear in situ.



Abrasion

Shoelace abrasion

Shoelaces that break are a frustrating problem and can spoil the performance of otherwise good footwear. Predicting the probable life of a shoelace or determining its abrasion resistance can be carried out using two abrasion techniques described below. Abrasion resistance gives a much better indication than tensile strength of the service life of a boot or shoelace. With SATRA test equipment, laces can be assessed for abrasion resistance using a shoelace to shoelace technique or, alternatively, a shoelace to eyelet method. Two machines are required to carry out the two tests and they are outlined here.

STM 152 Lace to eyelet method

This method utilises a standard eyelet mounted on a rigid board and the lace to be tested. Laces should be stored in a standard controlled atmosphere for at least 48 hours before testing. The equipment has six stations for testing laces. Eyelets affixed to rigid boards are placed in the holders provided. One end of the lace to be tested is clamped in a carrier and the other end is passed through the eyelet and then fixed to a weight capable of applying a tensioning force of 4.46N to the lace. The machine moves each lace a distance of 75mm through the eyelet at 100 cycles per minute. The movement of the carrier causes the lace to rub in the eyelet. Each station has a separate counter and, when a lace breaks, the count is stopped on that station. When all six laces have broken, the machine will stop. STM 152 is provided with hand control for ease of setting and is fully guarded to comply with European Health and Safety requirements. This machine can be used to test eyelets against standard shoelaces or alternatively shoelaces against standard eyelets.



STM 439 Lace to lace and lace to carrier methods

This method is a versatile test where two similar laces are abraded together. Laces should be stored in a standard controlled atmosphere for at least 48 hours before testing. One of the two laces used at each of the six stations has both ends of the lace clamped in the carrier provided. The second lace is threaded through the loop created by the first lace. One end of the second lace is fixed to a moving carrier while the other is attached to a weight that tensions the lace to 2.45N. When the machine is started the action of the moving carrier causes the two laces to abrade. The machine moves each lace a distance of 35mm at a frequency of 60 cycles per minute. Each station has a separate counter and, when a lace breaks, the count is stopped on that station. When all six laces have broken, the machine will stop. STM 439 is provided with hand control for ease of setting and is fully guarded to comply with European Health and Safety requirements. The same machine can be used to test the abrasion effects of rubbing the lace through a lace carrier or hook, for example eyelets, D-rings, ski hooks and others.



STM 633 SATRA/Martindale abrasion machine

This machine is ideal for determining the abrasion resistance of all types of fabrics and leather used for footwear, upholstery, clothing, gloves and many other products. The Martindale is the internationally-accepted test standard for wear of fabrics and it is also used for determining the susceptibility of fabrics to pilling.

The STM 633 can also be used for testing the abrasion resistance of rubber gloves, plastic and rubber coated fabrics by substituting the standard abrasant with a grit paper.

The machine can be used for soiling tests for light coloured materials. A specially inked fabric replaces the standard abrasant for this test.

An initial amount of the standard abrasive fabric is supplied with the machine.



STM 504 Motorcycle abrasion tester

The motorcycle abrasion machine allows an assessment of the initial impact and abrasion that may occur when a motorcyclist is involved in an accident and thrown from their machine. The abrasion of the road on the clothing being worn is replicated by a continuously-rotating, endless abrasive cloth belt.

Samples can be cut from the vulnerable areas of the motorcycle clothing – typically elbow and knee areas – which are fastened to a detachable sample head. The sample head is mounted on a cantilever mechanism which drops the samples onto the moving belt and exerts a static pressure on the sample of 25kPa. The machine is fitted with a timer mechanism that ensures the time taken to wear (abrade) through the sample is accurately recorded.

The cantilever mechanism and sample head can be moved across the abrasive belt to avoid testing on an already used part of the belt. To keep the belt free from debris during the test a large cylindrical rotating brush is in contact with the belt. A vacuum system fitted to the machine ensures the debris is removed safely.



STM 140 Leather soling abrasion machine

The SATRA soling materials abrasion machine gives a straightforward and realistic abrasion test for shoe soling and heel materials. The test pieces are drawn from side to side in a straight line under load over an abrasive coated cloth supported on the horizontal bed of the machine.

The cloth is moved slowly at right angles to the test piece so the test piece is always in contact with new abrasive cloth, maintaining constant cutting power.

The machine gives an average of abrasion through the entire thickness of samples. This can be achieved by abrading the two test pieces from alternative sides at the same time. Those pieces are 25mm (or 1 inch) square and the abrasive cloth is usually 80 grit. The loading on the test pieces is 0.56kg/cm² (8lb/in²). Dial gauges measuring thickness loss are a standard feature of the machine.

To ensure the test results obtained are accurate it is necessary to remove the debris caused by abrading the sample. This is achieved by applying a vacuum to the test area. The SATRA machine has a built-in vacuum extraction point where a normal domestic vacuum cleaner (not supplied) can be connected.



STM 602 Soling materials abrasion machine

This is ideal for testing rubber, urethanes and other synthetic solings to assess their resistance to abrasion in normal everyday wear. The principle of the test is simple but the unique three-head design of the SATRA abrasion tester reduces the time taken per test.

A 150mm diameter drum is rotated at 40rpm by a precision AC motor with variable speed control. A sheet of specified P60 abrasive paper (STM 469A or STM 469CA) is fixed to the drum by double-sided adhesive tape. A cylindrical sample, of fixed dimensions, is inserted in the sample holder and its protrusion adjusted and set using the integral micrometer. The sample holder either fixed or rotating, travels over the surface of the abrasive paper at 0.32m/sec under a loading of either 5 or 10 newtons for a set distance. An adjustable rotary cam allows the sample to travel 10, 20, 30 and 40 metres. On completion of the test the sample is removed and the volume loss determined by weighing and calculation.

The abrasive resistance of the compound can then be determined by relating the test results to those of a control compound (STM 469CR).

This SATRA machine has a self-tracking suction head which can be connected to a standard vacuum cleaner, removing the need for constant operator attention. A sample cutting knife is also available and is suitable for use with rotary pillar drill.

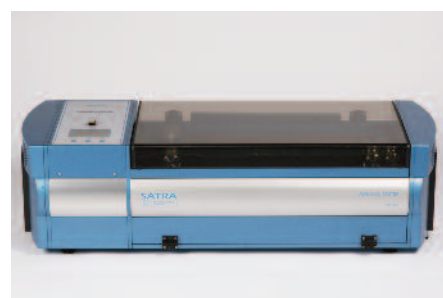

STM 164 Creep cabinet for testing adhesives

The cabinet is used to determine the heat resistance of adhesives (creep test) according to SATRA Test Method TM403. The method is equivalent to BS 5131 1.1.1 in most respects and is similar in principle to Method A4 of the Association of European Adhesive Manufacturers (FEICA).

It has been designed to provide all the test conditions required by the SATRA, BSI and FEICA test methods and will accommodate a maximum of ten test pieces.

The cabinet is a double-walled sheet metal construction with integral thermal insulation.

The top hinged front door comprises a single glazed unit. Toggle clips are fitted for door closure. The air in the cabinet is circulated by a crossflow fan/heater unit which provides a constant flow/temperature characteristic across all the specimens being tested. An electronic temperature controller with platinum resistance thermometer sensing element provides an accurate control of temperature (normally 60°C, but temperatures up to 80°C can be obtained).

The cabinet is usually mounted on a wall or other vertical surface and mounting brackets are provided.



STD 112 Adhesion of finish tester

Poor adhesion of the finish of an upper material can give rise to flaking or peeling in the shoe factory or in wear. Measurement of the actual strength of the adhesion is therefore important and the SATRA adhesion of finish tester enables this to be done reliably and simply. It has been adopted by the Society of Leather Technologists and Chemists (Method SLF 11) and the method has been recommended by the British Standards Institution as suitable for footwear materials in the introduction to BS 5131. It is also a test requirement for garment leathers in BS 6453: 1984.

The finish side of a strip of upper material is first stuck to a test strip (which can be of metal or PVC depending upon the adhesive used) using an adhesive which does not affect the bond of the finish to the upper material. Increasing static loads are applied to the upper material until it peels away, leaving the finish on the test strip. In some cases the top coat of the finish may be peeled from the base coat. The test is, therefore, very useful in the shoe factory for measuring the compatibility of shoe room dressings and of leather finishes.

Two methods of preparing the test assemblies are available and the actual composition of the apparatus depends on which adhesive is used.

The machine is supplied as standard set up to carry out the polyurethane adhesive test. If the epoxy resin adhesive test is required then the extra parts need to be ordered, Ref. STD 112A, together with resin and hardener, Ref. STD 112R and STD 112H.

A similar test is available utilising a tensile testing machine.



STM 124 Laboratory press for adhesive joints

The laboratory press was developed to aid the preparation of standard test pieces for adhesive testing, for example when using peel tests in conjunction with the SATRA tensile tester STM 566.

STM 124 is a vertical press operated by a pneumatic cylinder and develops thrust to approximately 1120kgf (2500lbs). A pressure regulator fitted to the press enables the thrust to be varied as required and a gauge indicates the operating pressure. Also incorporated into the control of this press is a cycle timer allowing the dwell time to be set. The moving platen is fitted with a thermostatically controlled heating element, and to comply with relevant safety requirements the machine is fitted with an interlock switch restricting access to any moving parts.

This press can also be used to cut out small specimens/samples used for tests – suitable knives are available from SATRA.



STD 185 Sole adhesion tester

This well-proven instrument is designed to measure the strength of the adhesion of stuck-on and moulded soles at the toe and heel of finished footwear in the shoe factory, but is equally useful in the testing laboratory.

The illustrations show the standard STD 185 with and without the heel attachment STD 185H. The sole of the footwear, still on its last, is positioned on the ridge shaped anvil or fulcrum so that the curved toe piece of the instrument fits in the feather-line groove between the sole and the upper.

A gradually increasing force is applied by hand to the backpart of the footwear and this effectively becomes a downward force applied by the toe piece to separate the sole from the upper. This force is shown by the load dial gauge on the instrument, which incorporates a maximum load pointer.

The actual load to cause separation can be measured or alternatively, a pass load can be applied to check that the sole adhesion is satisfactory and the sole does not come away. This second method of operation is the more useful one in the shoe factory since it can be applied to ordinary shoes from the production line. If, as should happen, the sole attachment remains secure, the shoes can be returned to the rack or track quite undamaged. If soles pull away before the pass load is reached, a check on materials, technique or process is called for.

The measurement of adhesion at the heel (mainly for men's and industrial footwear) is carried out in a similar way, but the heel is supported in a cradle (STD 185H), which replaces the anvil.



Colour fastness

STD 442 / STD 488 Colour fastness to water and perspiration

The fastness of colour when subjected to water and perspiration is a constant problem for manufacturers of footwear uppers and clothing and it can have disastrous and costly results. Materials can be checked easily and quickly using the equipment below to assess the likelihood of colour bleeding from a material when exposed to water or perspiration.

The test requires the material to be immersed in water or perspiration while in direct contact with standard materials. A weight is used to ensure the specimen is kept below the surface of the liquid throughout the duration. The specimen is subjected to a temperature equal to body temperature by a fan-assisted oven.

The test requires several items of equipment as described below:

STD 488 – Multi-fibre ribbon

This is a standard multi-fibre ribbon and is made up from six different standard materials:

- Filament spun cellulose acetate
- Bleached cotton
- Spun nylon
- Spun polyester
- Spun acrylic
- Worsted spun wool

STD 488P and 488G – Petri dish and glass weight

A standard size Petri dish and a glass plate (weight). The glass plate is the required weight and size conforming to the standard and is supplied ready calibrated.

STD 488I – Incubator oven

A commercial fan-assisted oven (0-300°C) capable of holding temperature to $\pm 2^\circ\text{C}$. The oven is supplied complete with shelves and digital PID temperature control.

STD 461GC and STD 461GS – Grey scales

These items are used to assess the amount of colour transfer or staining. Known as grey scales they conform to BS EN 20105 – AO2 (STD 461GC) & AO3 (STD 461GS).

STM 500 – Light cabinet

A standard light cabinet used for determining or comparing the transfer of colour or staining under standard light sources. This is used in conjunction with the grey scales described above. For a full description of STM 500 see page 20.



STD 442
Perspirometer

Colour fastness

STD 422 Crockmeter

This test is designed for determining the degree of colour which may be transferred from the surface of coloured materials to other surfaces by rubbing. The machine takes its name from the term 'crocking' meaning the transfer of colouring matter or other substances from the test sample to a wet or dry cloth rubbed against it.

The STD 422 consists of a base on to which a test sample is secured. A sliding mechanism is arranged to traverse a finger along the sample. The end of the finger is covered by a piece of cloth and a pre-determined load is also applied to the finger during the sliding motion. Coloured leathers are usually tested using a white bleached cloth – for white leathers a black colour-fast cloth is employed.

The movement of the finger is obtained from a cranked drive by means of a handle. A test would normally consist of 10 turns of the handle at 1 turn/second. Assessment of colour transfer is made using the grey scale.

The white cloth, STD422CL/500, used for rubbing and the grey scales are available from SATRA Test Equipment.

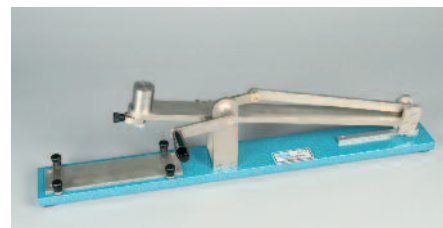

Compression set

STD 133 Compression set apparatus

Constant stress

During walking, a shoe sole (or top-piece) is subjected to compression forces and deformation due to flexing with each step, which temporarily increases its area. By the completion of the step practically all of this increase in area is lost. However, if the soling or top-piece is slightly plastic they do not completely recover and some of the increase in area is retained. Such a soling, therefore, gradually increases in size during wear.

There is no reliable single laboratory test which predicts the spreading behaviour of soles or top-pieces. Dynamic tests have been designed which apply repeated deformations as experienced during walking, but useful information can also be obtained from much simpler tests which use a single prolonged deformation. Such a test can either compress the sole with subsequent measurement of the permanent decrease in thickness, or stretch by measuring any permanent increase in length.

To accomplish these measurements easily and under standard conditions, SATRA has developed the compression set apparatus which can be used to assess solid, cellular and micro-cellular rubbers under constant stress conditions. Using this equipment sample discs are cut from the sole or top-piece material and are held between spring-loaded platens for a given time under a constant pressure. By using several spacers, tiers of specimens can be tested at the same time.

The thickness of the discs is measured before and after the test and the decrease in thickness provides an indication of the compression set of the material.

A suitable gauge for measuring the thickness under standard conditions is available, reference STD 495.



STD 401 Compression set apparatus

Constant strain

This apparatus is designed for constant strain compression set testing of rubber and rubber-like materials at room temperature and elevated temperatures.

This is achieved by placing each of three discs between two compression plates screwed together until stopped by a distance piece. The apparatus consists of a stack of alternate compression plates and distance pieces allowing five rubbers to be tested at once. They are all compressed in one operation by turning a single hand nut on a centre bolt.

Test pieces are held compressed for the specified time and, after release and a short recovery period, the new thicknesses are measured. The compression set of the material is the amount of compression retained, expressed as a percentage of the original thickness of the disc.

To facilitate the hand tightening, the base of the apparatus is made to fit into a holder screwed to the bench, but it is easily removed from this if the apparatus needs to be placed in an oven for a high temperature test. Alternatively, the base of the instrument may be screwed to the bench if used for room temperature tests only.

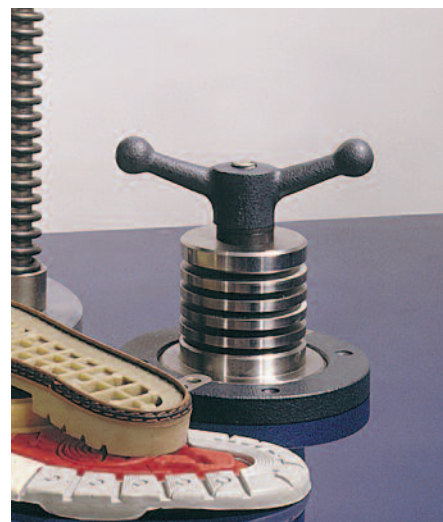

STM 579 Hosiery compression tester

Compression hosiery is commonly used to offset the effects of varicose veins, but also has other medical applications, such as helping to reduce the potential for artery blockages caused by blood clotting (embolisms) during operations. This form of hosiery is also becoming popular for people to wear as a preventative measure against deep vein thrombosis (DVT) on long-haul flights

Three standards, BS 6612:1985 – ‘Specification for graduated compression hosiery’, BS 7563:1999 – ‘Specification for non-prescriptive graduated support hosiery’ and BS 7672:1993 – ‘Specification for compression, stiffness and labelling of anti-embolism hosiery’, require the use of the HATRA pressure tester, which was developed by the (now defunct) Hosiery and Allied Trades Research Association.

SATRA STM 579 has been developed to be used in place of the HATRA Hose Tester MkII which is no longer available.

The device consists of two main parts – a garment former and a measuring head. The hose is loaded onto the adjustable former, simulating the wearing of the garment on a human leg. The measuring head is pressed against the stretched fabric at various points along the length of the leg and displays a value for circumferential tension in the fabric, The results are converted to give a value for pressure.



STM 512 Repeated compression testing machine

The SATRA STM 512 test machine is a two-station machine, which simulates the forces applied by repeated heel strikes in walking. The machine can test whole shoe constructions or heel components, as well as evaluating sheet materials for midsole use.

The load is applied with a pneumatic plunger via a domed striker to represent the human heel. A standard test is run for 500,000 cycles and the applied load can be varied to replicate the forces attributed to men, women or children, and the strike rate can be increased to accommodate accelerated testing or the assessment of running shoes.

Evaluation of footwear, when using the STM 512 can be in the form of failure due to collapse or splitting. Another characteristic of footwear that can become evident when using the STM 512 is the compression set of the footwear material. Compression set can be seen as the permanent loss of thickness of a material or component measured after a period of recovery following cyclic compression.

The STM 512 can be used to help identify suitable materials for use in the construction of footwear and also used in conjunction with other SATRA test machines to produce ageing prior to other tests being undertaken, for example, shock absorption tests as conducted using SATRA STM 479.



Conductivity

STD 464 Simple conductivity tester

This equipment has been developed to allow non-destructive testing of conductivity and anti-static properties of footwear outsoles, within a production environment. The simple conductivity tester consists of a probe and a wet/dry pad to place the sample on during testing.

A meter is NOT supplied with this equipment, and this equipment is designed to operate in conjunction with STM 470.



Conductivity

STM 470 Conductivity tester

The SATRA conductivity tester assesses the electrical resistance and antistatic properties of footwear outsoles and sheet material.

The test is simple and easy to use, with testing undertaken in a controlled environment of temperature and humidity. A meter to measure the resistance of the outsole is included and the test result is displayed on the screen. This equipment is intended for laboratory use and is not suitable for production line environments.

An alternative item, STD 464 is available and suitable for use in production environments.

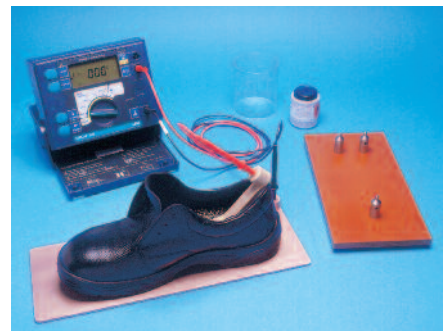

Contact heat

STM 531 Contact heat tester

This test machine is designed to assess the result of heat being applied to sample materials under a constant force and allows tests to be conducted to the requirements of EN 702 (referenced in EN ISO 20349, for example, which includes foundry and welding boots).

The device, designed and manufactured by SATRA Technology, comprises a frame on which the contact heat mechanism is mounted.

An electrically-heated block, with temperature adjustable up to 500°C, is automatically lowered onto the surface of the test specimen at a constant speed. This block is of a size and weight so that the total contact force of the block is $48 \pm 0.5N$ in accordance with the test standard.

A timed system is incorporated so that the block rests on the test specimen for a pre-set time, after which it is automatically raised. The test specimen is mounted on a calorimeter connected to a display unit to show the heat that is transmitted through the specimen.



Cut resistance

STM 611 Circular blade cut resistance tester

This machine measures the cut resistance of a material in accordance with EN 388 (Clause 6.2).

A test sample is clamped in an easily removed holder. The holder is then placed onto the machine. The circular blade is gently lowered so that it touches the test sample. With the counter set to zero the 'Start Test' button is pressed to initialise the test. When the rotating blade penetrates the test sample the machine will automatically stop. The number of cycles displayed on the counter screen is used to produce the cut index which is a measure of the material's cut resistance. See also page 13.



STM 610 Cut resistance evaluator

This tester applies a cut to the sample with a straight blade. A number of cuts are made each using a new blade and using a different contact force. A graph is then plotted of cutting stroke length compared to blade loading to predict the force at which the blade will just penetrate the material at 20mm stroke. That force in newtons gives the cut index and EN 388:2003 includes a potential correlation with the blade cut index value such as that produced by STM 611. See also page 13.



STD 206 Quarter and back height gauge

The height of the top-line of a shoe at the back and at the quarters affects fit and comfort. If the back height is too low heel slip may occur during walking. If the quarters, particularly the outside quarter, are too high the top-line may rub the ankle bone.

The STD 206 is an instrument designed to measure the height of the top-line of the shoe above the insole surface at the seat to check that footwear is satisfactory. It can be used for all sizes of shoe and incorporates an adjustment which allows the measuring positioning for quarter height to be varied correctly with shoe size. It can be easily changed to measure left and right shoes as required.

To carry out measurements the gauge is placed inside a shoe on the insole at the seat. It is a simple but accurate device and is supplied with full instructions and tables giving measurement positions for adults' as well as children's shoes. It is nickel plated to prevent corrosion.



STD 225 Internal shoe size gauge

This simple and easy to use device is used to determine the size of footwear. The flat bar is inserted in the shoe and pushed into the toe. The slider is then moved along the scale until the curved bar touches the heel. The longest length can be found by moving the device vertically and locating the curved bar to the point of maximum heel curvature. At this point the size of the footwear can be read off the scale. There are four versions of the internal shoe size gauge which cover the adults' sizes 11-14 and children's sizes 3-7:

STD 225E	Adults' scale in English sizes
STD 225M	Adults' scale in millimetres
STD 225C	Children's scale in English sizes
STD 225CM	Children's scale in millimetres.



STD 224 SATRA fitting board

An effective fitting board is invaluable to shoe retailers. It enables them to quickly establish the size of shoe most likely to fit the customer.

Many fitting boards are specific to a single manufacturer's range. The SATRA fitting board, however, is based on established guidelines and produces correct standards of fitting so that individual ranges of footwear can be related to it. SATRA's extensive and unique knowledge of the requirements for good shoe fitting ensure that the STD 224 fitting board is ideal for retailers.

The absence of moving parts coupled with the robust design, ensure long and trouble-free use. The fitting board is produced in MDF (Medium Density Fibreboard – reconstituted wood) with an ash veneer. The size markings are reverse printed onto a clear label ensuring that the attractive wood grain shows through while the print is protected from wear. Multi-coloured width bands coupled with size marking make this unique fitting board attractive and simple to use. The width fittings are arranged in five unique bands: Extra narrow, Extra wide, Wide, Average, Narrow. There are three standard fitting boards to cover the men's, women's and children's size ranges:

STD 224M	Men's shoe sizes
STD 224W	Women's shoe size
STD 224C	Children's shoe sizes

For customers requiring larger quantities of fitting boards it is possible to customise the standard SATRA fitting board to incorporate specific size ranges, width fittings, colours, own logos or company messages. The cost is only marginally more than the standard fitting board when quantities of 50 or more are ordered, subject to the number of different colours and design work.



Fitting

STD 219 Size stick

When customers try on shoes at the point of purchase it is important to ensure that the buyer's foot length is appropriate for the shoe being considered. The SATRA size stick is a convenient way to achieve this. Shaped like a calliper, this device has dual scales – English shoe sizes and millimetres. Since the foot spreads when a person is standing this is the best way to measure the foot (with weight on). The scales on the SATRA size stick are adjusted to measure feet in this way. Both left and right feet can be measured using the device and the scales are so angled that either scale can be easily read.

The SATRA size stick is easy to use – simply place the fixed anvil behind the heel and move the sliding calliper up to the longest toe and read the indicated size.



STD 223 Digital last assessment jig

This provides the appropriate platform to take specific last measurements and ensure the last conforms to the required standard. Lasts and the shoes made on them must match the feet they are intended to fit. SATRA's extensive surveys enable lasts to be checked without the need for extensive fitting trials. This is achieved by checking several key last dimensions when the last is standing with the heel raised as in wear. SATRA's last assessment jig provides accurate repeatable dimensions using two digital readouts on both left and right foot lasts.

The jig is manufactured in aluminium and clear plastic sheet. There are two built-in digital slides, both of which can be zeroed at the appropriate datum position. It also incorporates an angled measurement device that facilitates the location of the last joint line. A separate pair of digital callipers and a toe spring gauge are also supplied.



Flexing

STM 129 Fibreboard flexing machine

This is an excellent test for fibreboards such as insole foreparts normally flexed or deformed in wear. The machine assesses quality and durability by repeated flexing of the specimen through 180°. The machine can also be used to determine the effect of heat on the insole caused by direct-on moulding or vulcanising.

The six 10mm wide test pieces are clamped in the jaws and a 2 kilogramme weight is suspended on the lower end. During the test, the jaws are rotated through 180° (90° each side of vertical) until the test piece breaks. Each sample has an individual counter which stops when the sample breaks. This indicates the number of flexes to failure of each test piece.



STM 441 Midsole flexing machine

This determines the flexing properties of penetration-resistant inserts (midsoles) used in safety footwear. The SATRA STM 441 is a six station machine with two banks of three stations on either side of the central body of the machine. The inserts, usually of steel, are located in the machine clamps, together with the correct interlayers (supplied) and free end resting against the flexing bar. The angle of flex can be adjusted to meet the appropriate standard.

A timer is provided to stop the bar once the required number of flexes has been reached so that the inserts being tested can be inspected. The machine is designed to operate at 16 cycles/second.



STM 141 Ross flexing machine

This machine is used to measure the resistance of non-leather shoe soling to cracking in wear due to flexing and can test 12 strip test pieces at a time. This machine can also be used to test whole soles. It normally runs at 60 flexes/minute, but for tests to ASTM standards a motor to give 100 flexes/minute can be fitted.

This test should nearly always be carried out at low temperatures so a model, STM 141F, is fitted into a refrigerated cabinet with the motor drive and control on the outside of the cabinet (see page 21).

For Chisel holding jig STD 405, see below.



STD 405 Chisel holding jig for preparing Ross flexer test pieces

The Ross flexing test for soling materials requires an initial cut of the particular size to be made in the test piece in the correct position. This jig enables the cut to be made easily and in the correct position without the need for measuring the test piece.

The jig base is provided with a longitudinal slot into which the test piece can be placed and located against an end stop. The chisel is then guided by the pins to ensure that the cut is made correctly.

The end stop is removable so that the cut can be correctly positioned for either the SATRA or the ASTM Ross test.

Two types of chisel are available to fit the holder and spares are always kept in stock.

The reference numbers for the chisels are:

STD 405S for the SATRA Ross test

STD 405A for the ASTM Ross test.

The chisels should be ordered separately.

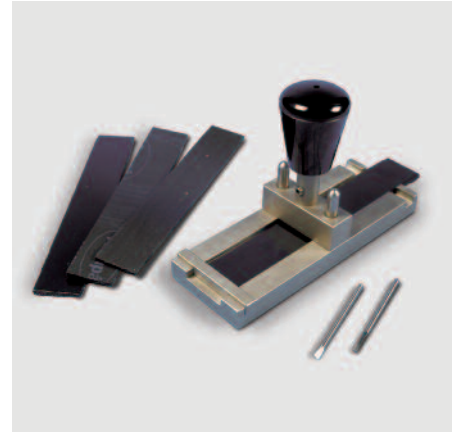

STM 612 SATRA/Bata belt sole flexing machine

The SATRA/Bata belt flexing machine provides one of the best indications of the risk of cracking of shoe soles due to flexing in wear. The test is conducted by fixing the sole unit to an endless belt which passes around two pulleys of differing diameters. The larger main drive pulley provides the rotation while the smaller of the two pulleys determines the severity of the flexing action. The equipment is supplied complete with three small pulleys of varying diameters to increase or decrease the amount of flexing.

The endless belt can usually accommodate six sole units, subject to the style and size. Sole units are bonded to the belt using a strong adhesive. When very stiff sole units are tested it may be necessary to stitch the toe of the sole unit to the belt.

The belt is made of canvas and its construction allows the number of complete cycles to be counted which is equal to the number of flexes of the test sample.

The flexing area is provided with a full guard interlocked with the machine controls to ensure the guard cannot be opened until the belt has stopped.

The control cabinet located at the side of the machine houses the motor drive controls as well as a counter which can be pre-set to stop the machine when a predetermined number of flexes has been reached. This allows the examination of the sole units at intervals throughout the test duration.

The standard machine is supplied as a bench top machine, although a separate stand can be supplied at additional cost.

A low temperature variant allows the flexing to be carried out at sub-zero temperatures, enabling the increased risk of cracking due to cold weather. The complete flexing mechanism is built into an insulated chamber where the temperature can be reduced to a pre-set level. The lowest temperature achievable on this model (STM 612F) is -20°C subject to ambient temperature. STM 612F is supplied complete with a stand that houses the refrigeration unit.

The machine is suitable for the testing of all shoe sole units and can also be used with other flexible materials.



Flexing

STM 601 SATRA vamp flexing machine

This assesses the tendency of all types of upper materials, clothing leathers and upholstery coverings to crack or break as a result of flexing in wear. It is equally suitable for testing leather, plastic coated fabrics, polymeric and woven fabrics. This method can also be used to test seam construction during flexing. The crease formed by this method is an accurate representation of those formed in normal wear. The machine configuration allows a minimum of eight samples to be tested simultaneously and it is fitted with a counter which allows the total number of flexes to be pre-set.

STM 601/12 12 station version
STM 101/F 16 station in freezer cabinet to -20°C (see page 21)



STM 701 Bally flexometer

The SATRA Bally flexometer is the internationally-accepted method for the assessment of the flexing endurance of light leathers and their surface finishes. The tendency for cracks to form in the creases caused by walking can also be determined. The Bally flexer has a different flexing mechanism to the SATRA vamp flexer (STM 601) and is complementary to it. It is also used to precondition samples prior to determining water vapour permeability – particularly in assessing uppers for protective footwear.

The twelve stations are conveniently arranged for user access and sample mounting. A pre-determined counter is fitted to the machine, allowing it to be operated without continuous attendance as the machine stops automatically once the set count is reached.

The machine is simple to use, bench mounted and supplied ready to connect to the electrical supply.

There is a four station version of this machine (SATRA Ref. STM 702). Low temperature versions are also available (to -20 °C) subject to ambient temperatures in location of machine (see page 21).



STM 184 Whole shoe flexing machine

The STM 184 flexing machine has been developed to assess the flexing endurance of completed footwear in wet and dry conditions. The machine is supplied in both single or twin station formats and the action simulates the flexing of footwear during wear. The angle of flex is adjustable up to 50°. The machine may be used to predict the failure of footwear in wear. It is particularly useful in assessing problems associated with bottom construction. Footwear is clamped to the machine at the toe end using the appropriate toe clamp from one of five pairs supplied. The heel end is secured to the flexing bar. A predetermining counter is fitted and once the appropriate number of flexes has been registered, it will stop the machine so that the shoe can be inspected. The moving parts of the machine are covered by a hinged guard which is fitted with the latest safety device to prevent access while the machine is still in use. The machine is robust and non-corrosive materials are used where applicable in its construction.

A similar machine is available for testing high leg boots (STM 184H) where water depth can be increased to cover the whole forepart of the footwear up to eyelet level. Details available on request.

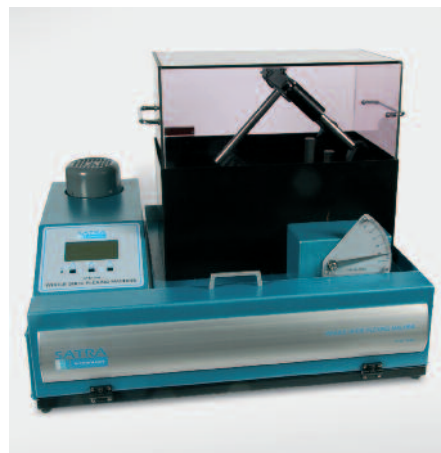

STM 465 Whole sole flexing machine

This is used to determine the resistance of materials to cut growth during repeated flexing. It is especially applicable to outsoles of protective footwear. The machine has three workstations presented horizontally for operator ease. Loading, unloading and measurements are also much easier to carry out with the workstations presented in this manner. Samples are set at 140 flexes per minute and the number is recorded on a counter which has the facility to pre-set the number of flexes required. A jig, STD 465J, is available and is used to locate the chisel STD 465C and support the test while the initial chisel cuts are made. All moving parts requiring access are protected by a fully interlocked safety guard, ensuring the machine conforms to the latest safety regulations. A manual device to measure the stiffness of outsole may be required to see if outsole must be flexed in accordance with EN ISO 20344.

SATRA also provide a version of this machine for testing at low temperatures (STM 465F) allowing tests to be conducted down to -20°C.



EN 388 Testing protective gloves intended for the European market

EN 388 is the European standard for testing protective gloves against mechanical risks.

You can perform the complete set of abrasion, cut, tear and puncture tests at source with SATRA test equipment.

STM 633 Martindale abrasion tester

This machine will determine the abrasion resistance of all types of material used for protective gloves in accordance with EN 388. It is the internationally accepted test standard for wear of fabrics and it is also used for determining the susceptibility of fabrics to pilling.



STM 611 Circular blade cut resistance tester

This machine measures the cut resistance of a material in accordance with EN 388 (Clause 6.2).

A test sample is clamped in an easily removed holder. The holder is then placed onto the machine. The circular blade is gently lowered so that it touches the test sample. With the counter set to zero the 'Start Test' button is pressed to initialise the test. When the rotating blade penetrates the test sample the machine will automatically stop. The number of cycles displayed on the counter screen is used to produce the cut index which is a measure of the material's cut resistance.

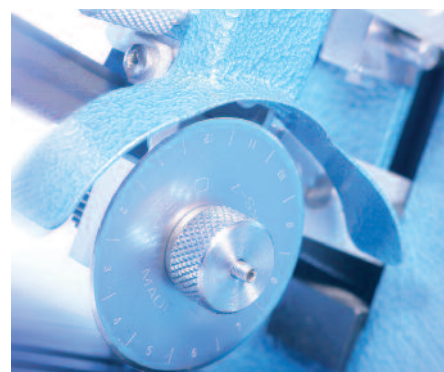

STM 610 Cut resistance evaluator

This tester applies a cut to the sample with a straight blade. A number of cuts are made each using a new blade and using a different contact force. A graph is then plotted of cutting stroke length compared to blade loading to predict the force at which the blade will just penetrate the material at 20mm stroke. That force in newtons gives the cut index and EN 388:2003 includes a potential correlation with the blade cut index value such as produced by STM 611.



STM 566 Tensile tester

The tensile tester is probably one of the most versatile machines used in a laboratory. The STM 566 is capable of carrying out tests where measurement of extension or compression against load is involved. The SATRA tensile tester can perform many tests required by a wide range of standards and is complemented by a full range of associated tensile jaws. Special jigs are available to enable the tests in EN 388 Clauses 6.3 and 6.4 (tear and puncture resistance) to be carried out. The machine is a twin column machine for extra strength and has been designed to be user-friendly with simple software operating the machine from a PC (not supplied). Each screen output to a PC shows real time data and graphs are displayed to allow constant monitoring of information gathered.

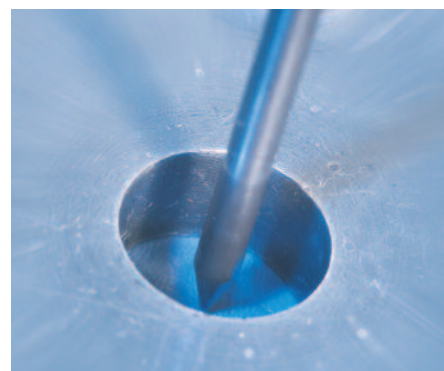

Durometers

SATRA supplies a unique range of hand-held and bench-mounted durometers for measuring the hardness of rubber and plastic materials. Manufactured at our own headquarters, the range of durometers has a patented interchangeable module allowing the complete range of Shore hardness scales to be measured on one instrument. Each module supplied with the instrument is calibrated to the instrument head, making the complete device ideal for checking incoming material hardness either on site or at the supplier's premises.

A range of operating stands and control systems are available to support the durometer range. These improve repeatability and accuracy of the hardness measurement.

The range is available in either digital or analogue versions.

For convenience we have identified the most popular ranges and given them a SATRA reference. Where this does not meet your exact requirements you can order the items separately, such as a digital head with A scale module.

Choosing the right durometers couldn't be easier: Our patented interchangeable module system makes this instrument the ideal choice for you.

Step 1: Select digital or analogue instrument head.

Step 2: Specify with or without maximum pointer for an analogue instrument.

Step 3: Select one or more modules to suit your requirements. These will be calibrated to suit the chosen instrument head.

DIGITAL DUROMETERS

STD 226 – A digital durometer with interchangeable modules which can be chosen from the selection below. Choice of module(s) will depend upon the type (softness) of material being tested.

Features:

- Resolution – half of one degree Shore hardness scale
- Easy to use – hand held
- Sturdy, accurate and reliable
- Has a BCD output facility
- Uses 1 x SR44 flat battery
- Multiple modules with the same instrument head
- Shirt pocket size for easy carrying
- Dimensions – 135mm x 38mm x 23mm
- Weight – 220g
- Supplied in convenient storage/protective case

MODULES

Shore A Scale	SATRA TM 205	ASTM D 2240	ISO 7619 & 868
Shore B Scale		ASTM D 2240	
Shore C Scale		ASTM D 2240	
Shore D Scale		ASTM D 2240	ISO 7619 & 868
Shore DO Scale		ASTM D 2240	
Shore O Scale		ASTM D 2240	

ANALOGUE DUROMETERS

STD 227 – An analogue durometers with a choice of maximum pointer and interchangeable modules which can be chosen from the selection below. Choice of module(s) will depend upon the type (softness) of material being tested.



Features:

- Resolution – one degree Shore hardness scale
- Supplied complete with tolerance settings
- Optional maximum hand
- Optional stand for improved repeatability
- Dimensions – 150 x 65 x 25mm
- Weight – 300g
- Multiple modules with the same instrument head

MODULES

Shore A Scale	SATRA TM 205	ASTM D 2240	ISO 7619 & 868
Shore B Scale		ASTM D 2240	
Shore C Scale		ASTM D 2240	
Shore D Scale		ASTM D 2240	ISO 7619 & 868
Shore DO Scale		ASTM D 2240	
Shore O Scale		ASTM D 2240	

Each durometer sold comes with its own calibration certificate pertaining to the relevant module. SATRA also undertakes a recalibration programme, where instruments are returned to us. For further details contact test.equipment@satra.co.uk

STM 455 Heat resistance tester

The heat resistance tester is ideal for assessing the effects of heat on outsole and upper materials. Heat is applied to the sample via a heated square pad manufactured in copper.

When testing rubber and polymeric outsoles in accordance with the standard, the material should not melt and no cracks should develop when the tested outsole is bent around the mandrel supplied. In the same way leather outsoles should not develop cracks or charring when bent around the same mandrel.

The heated copper pad is of constant mass and incorporates a temperature indicator. An additional weight fixed to the moving arm ensures that the same pressure is applied to all test pieces. Provision is also made for holding the copper pad above the test pieces between tests.



Humidity

STD 228 SATRA Sensor

The SATRA Sensor is a self-contained miniature sensing system for remote monitoring of air temperature and humidity. It is designed to monitor in-factory processing conditions, for example cement drying or heat setting tunnels in footwear manufacturing. It will also monitor environmental conditions encountered by products during storage or transit, for example in seaborne containers.

Benefits of using SATRA Sensor:

- Assures product quality through monitoring of critical process conditions involving heated air and/or moisture
- Monitors conditions to which products are subject in storage or transit – important where leather, textile and timber products are concerned
- Provides easy to understand records of process/storage conditions for tracking quality
- Robust and tamperproof; it can be used over and over again.

SATRA Sensor incorporates sophisticated re-usable monitoring equipment for recording temperature and humidity over periods ranging from a few seconds to several months. It has no wires and can thus be used to monitor conditions in conveyor-type processes or areas where access during the measuring period is difficult. It can record changes in ambient temperature or cope with processes up to 120°C. The temperature and humidity data recorded on the SATRA Sensor can be quickly downloaded to a computer and displayed for analysis, archiving and printing. The recorded parameters can be calibrated and the type of data recorded can be selected to reflect individual requirements.



Impact

STD 155 Heel impact tester

This device is used for determining the resistance of heels to sudden impact loads in wear caused by abnormal stresses.

STD 155 has been extensively used for heel development and quality control.

The heel under test is held rigidly at the seat in a fusible alloy clamp (supplies available from SATRA Ref: 303976) in a position which allows the falling pendulum/striker to strike the heel in a forward direction approximately perpendicular to the stem and 6mm from the tip of the heel. The complete clamp is fully adjustable to accommodate any normal heel design.

The normal method of testing is to subject the heel stem to successive impacts starting at 0.5 joules and in increments to a maximum of 19 joules.

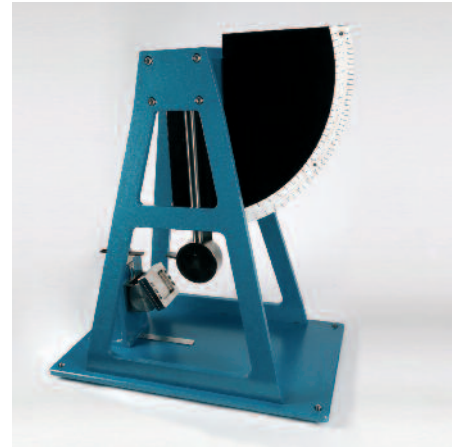

STD 156 Heel fatigue tester

Some high heels are prone to fatigue under the repeated small deformations produced by each step in walking. This machine is designed to check the fatigue resistance of such heels by subjecting them to continuous small impacts which produce similar deformations to those of wear. It is now a well established and valuable test.

The heel is held rigid at the seat in a fusible alloy in one of three special holders provided. A melting pot STM 156MP is required to melt the fusible alloy prior to pouring the alloy around the heel seat. Adjustments are provided so that the heel, whatever its size or shape, can be set to receive forward impacts at the back of the stem, 6mm from the tip and perpendicular to the stem direction.

The standard impacts of 0.68 joules are delivered at one second intervals by a striker attached to a free falling pendulum. This is lifted mechanically between each drop and automatically caught on the rebound. When the heel breaks, the machine switches off automatically and a counter indicates the number of blows to cause failure.

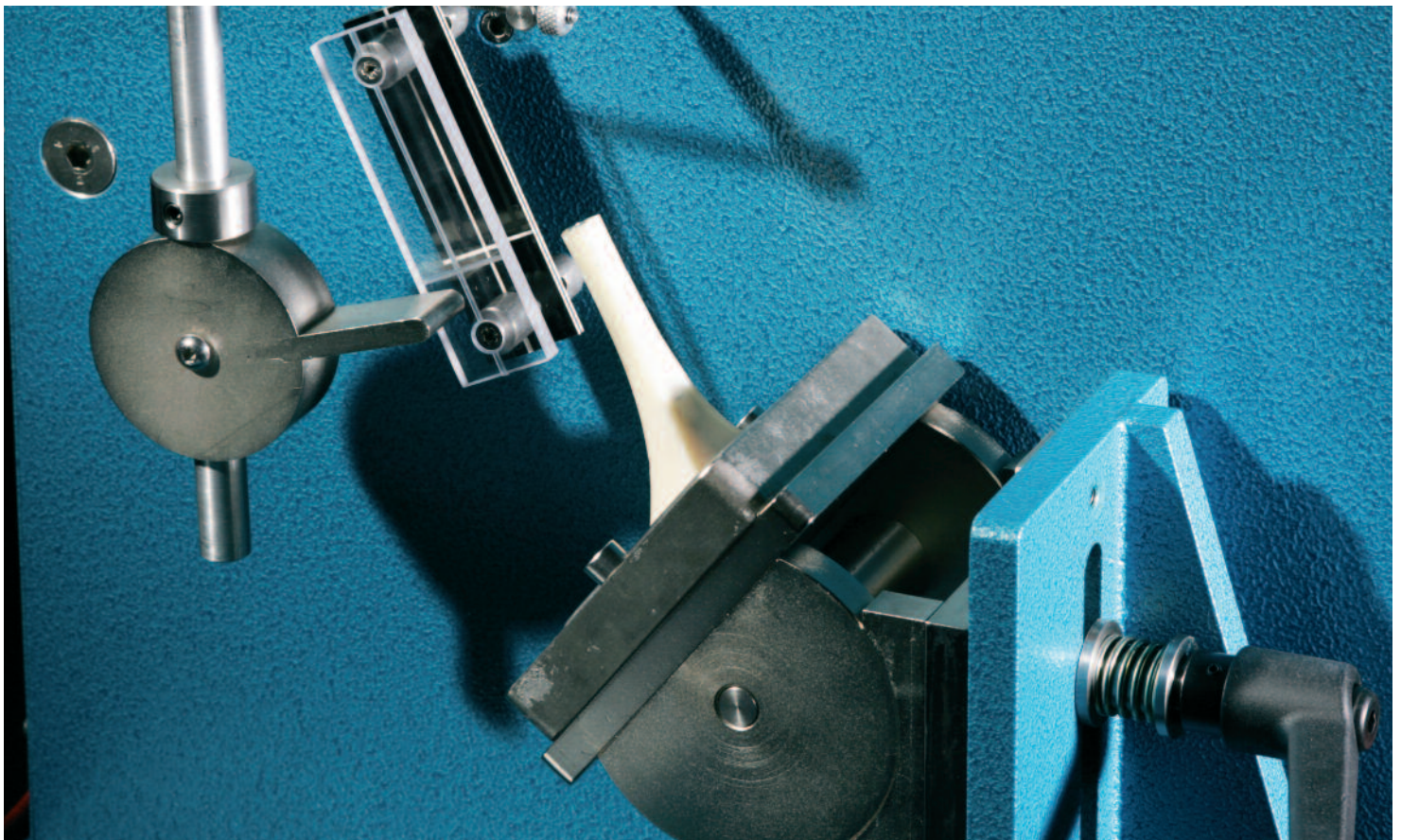

STM 609 Safety footwear impact tester

This equipment can be used for a variety of impact (drop) tests with the appropriate anvils and strikers. It is ideal for testing to safety footwear standards and meets the full requirements of the latest revisions to a number of standards.

This machine from SATRA's extensive range replaces STD 409 and incorporates many features not found on that model, including motorised lift of the striker mechanism which moves automatically to a pre-set height and includes a speed sensor that will determine if the correct impact energy has been achieved.

A slide mechanism ensures minimum frictional losses and it also incorporates a belt drive system to provide the striker drop height position. The guarding provides complete operator safety while giving full access to the anvil area for ease of setting up each test. An anti-bounce device prevents a double impact strike on the footwear under test.

The machine is supplied as standard with all the anvils and strikers required.

The impact test rig is mounted on a secondary steel block weighing approximately one tonne. This block can be provided with the machine at additional cost or a drawing can be provided for local supply or manufacture.

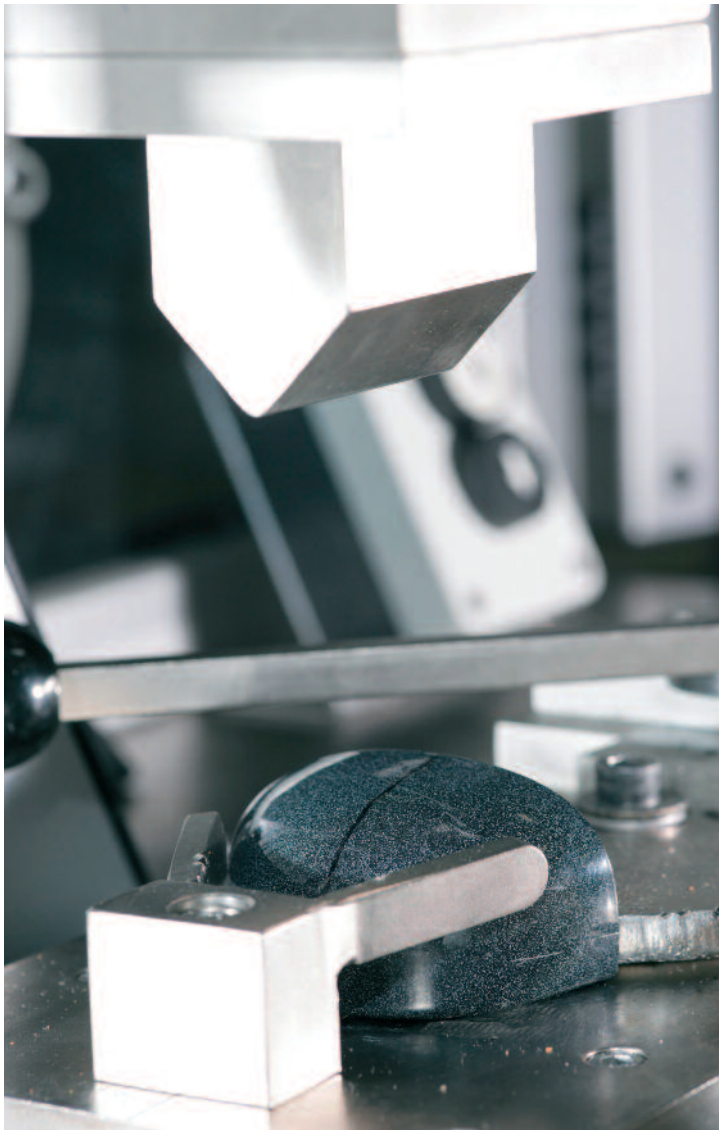

Insulation

STM 471 Heated sandbath

This bath is designed to assess the heat insulating properties through the soles of safety footwear. The apparatus consists of a thermostatically-controlled hot plate covered with sand. The footwear is placed on the hot plate so that the sand covers the featherline. A separate temperature probe, connected to a digital readout via a plug and socket arrangement, is placed inside the footwear to measure the temperature rise over a specified time.

The sandbath incorporates an illuminated power on/off switch and a temperature controller. The digital display for the separate temperature sensing probe is also located on the control panel. The separate temperature probe is supplied with the equipment, along with a sufficient quantity of steel balls which are packed inside the footwear during the test.

A fitted mesh guard protects the operator from the heat source during testing.



STM 472 Cold insulation tester

This machine is designed to assess the insulation properties of footwear against cold temperatures. The equipment forms part of a suite required by the safety footwear standard, but can also be used for any application where footwear needs to withstand cold temperatures.

The equipment comprises a freezer cabinet capable of achieving -20°C (subject to ambient temperatures), a measuring probe to measure the internal temperature of the footwear and steel balls used to fill the footwear under test. The footwear is placed in the freezer cabinet, using the jack table provided, so that the open part of the footwear protrudes through the opening in the inner lid. The probe is placed on the insole. Temperature of the insole is shown on an LCD display located on the control cabinet. A digital temperature controller with a built-in display accurately controls the freezer temperature and the difference between the freezer temperature and insole temperature determines the amount of thermal insulation.



Lastometers

STM 463 Digital lastometer

The two-dimensional stretch of footwear materials can be tested faster and more accurately using SATRA's digital lastometer. Specimens cut from the material are placed in the machine in accordance with the instructions and the results are displayed on the machine LCD panel and also on the print provided at the end of the test. Designed to measure the tendency of an upper material to crack or burst during the lasting process, this lastometer incorporates a series of features not available on other models and is ideal for multiple tests carried out in today's modern laboratory:

- An electronic menu-driven system displaying continuously updating test information on an LCD panel
 - Load and distension data may be downloaded via a USB output
 - Tests several samples and calculates an average load, distension and standard deviation.
- The digital lastometer can be set to provide load results in kilogrammes or newtons while distension is displayed in millimetres. An optional graph of the test is also available. STM 463 allows multiple testing of batches of 3, 4, 6, 8 or 10 samples or single test pieces.



STD 104 Lastometer

This machine is a simpler manual form of the digital lastometer and is a mechanical device. Specimens cut from the material are placed in the machine in accordance with the instructions provided. The ball-ended rod is raised by turning the machine handle. The load, measured by a sealed hydraulic system, is displayed on an analogue dial with maximum pointer. A mechanical counter geared to the movement of the ball-ended rod records distension. The equipment provides all the necessary information to determine the suitability of the specimen material for lasting, but does not have a motorised drive.

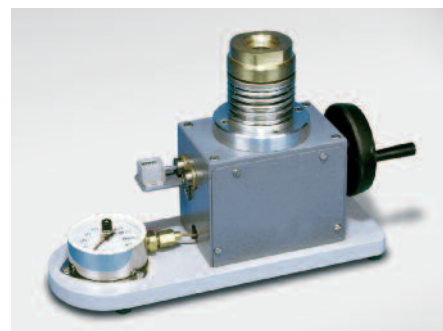

STD 190 Instant lastometer

Simplified form of the STD 104. This device, intended for use as a simple pass/fail gauge, can be used in an incoming goods area for testing leather hides or sheet materials. Used in conjunction with the normal laboratory tests, this can provide a valuable quality control check, rejecting unsuitable materials before they enter the manufacturing cycle. The test is not destructive.

The instant lastometer is pneumatically operated via a pushbutton mounted on the frame and the user can select one of three preset distensions of 6, 7 or 8mm. When operated, the device clamps the material and pushes the ball-ended rod into the specimen. If the surface of the material cracks or tears, the material is unlikely to be suitable for lasting. The chosen pre-set distension value should be established by carrying out full laboratory tests.

A filtered and lubricated air supply is recommended for instant lastometers to prevent damage to the internal mechanisms.



STD 190L Instant lastometer (extended throat)

Simplified form of the STD 104. This version provides exactly the same benefits and results as its partner STD 190. The STD 190L has the added benefit of an extended throat, allowing tests to be carried out anywhere on the incoming material.

The device, intended as a bench top unit, is provided with a foot-operated treadle to carry out tests, leaving both hands free to move the material being tested.



Leather analysis

STM 145 Shaking machine for leather analysis

This machine is used to extract water soluble materials from leather by the method of analysis specified in many national and international standards.

The leather must first be ground using a suitable grinding mill (available from SATRA) and then shaken with water in a vacuum flask to extract the soluble matter (using the shaking machine STM 145). The use of vacuum flasks keeps the liquid at the specified temperature during the extraction process. The machine accommodates eight flasks (supplied with the machine) and rotates them at 50rpm in an over-tumbling action.

The same machine can be used to determine the pH (acidity) levels in leather for which additional equipment is required. Leather pH levels require the use of a small plastic flask and an adaptor to enable the flask to be used in conjunction with STM 145 (available on request).



Leather assessment

STD 114 Apparatus for leather shrinkage temperature determination

If a strip of leather is slowly heated in water a sudden shrinkage occurs at a temperature which is characteristic of the tannage. Generally, the higher the shrinkage temperature, the better the heat resistance of the leather, so measurement is useful for judging the suitability of leather for different footwear manufacturing processes and particularly for moulded-on footwear.

Frequently, the shrinkage temperature is above 100°C and has to be determined in water under pressure. This is the special feature of the SATRA apparatus which measures shrinkage temperatures up to 115°C.

The apparatus consists of a vertical sight glass, connected by tubes to a smaller boiler which can be heated by a bunsen burner (not supplied), so providing a convection circuit of heated water.

A strip of leather and a thermometer are suspended in the sight glass, the upper end of the leather is fixed and the position of the lower end is indicated by an adjustable marker outside the tube to help judge when shrinkage occurs.

A safety valve is fitted to the apparatus which limits the pressure to that corresponding to a temperature of 120°C.

A perspex guard is provided around the sight tube as a safety precaution.



STD 119 Wrinkleometer

This is mainly used to assess the tendency of upper materials to form pleats or wrinkles where 'shortening' occurs during the lasting operation, especially around the toe and seat areas. It is particularly useful for testing synthetic upper materials which are prone to this problem.

A strip of upper material is held between two clamps. They are brought together by a pre-determined amount to correspond to the shortening. A perspex bar is then pressed down and the material can be checked for folds or wrinkles. The degree of shortening is increased progressively until unacceptable wrinkles occur.



Light cabinet

STM 500 VeriVide colour assessment

Used for the visual assessment of colour under standardised conditions, this cabinet is recognised as an industry standard. It features membrane switching and electronic ballast control of the lamps. Combinations of 26mm or 38mm lamps can be installed. The cabinet accommodates up to four different light sources. This cabinet meets a variety of standards and includes a fixed 45° specimen table and hour meter as standard. Specify lamp combinations from the table below when ordering or a standard lamp combination will be supplied.

Standard lamps (Colour temperature approx.):

D65	Artificial daylight (1 Level)	6500°K
D652	Artificial daylight (2 Levels)	6500°K
N	Point of sale lighting (natural lamp)	4000°K
TL84	Point of sale lighting	4000°K
TL83	Point of sale lighting	3000°K
F	Filament (domestic) lighting	2300 to 28000°K
UVB	Ultra-violet	
HM	Hour counter.	

Standard lamp combinations: D652FUVB/HM D65NFUVB/HM D65STL84UVB/HM
D65TL83UVB/HM D65TL84FTL83/HM D65UVBFUVB/HM D65TL83FTL84/HM

N.B: A second level of daylight is recommended for colours of low reflectance. Filament lighting is required as a test for metamerism. The ultra-violet lamp is used to reveal the presence of fluorescent dyes and bleaches. Alternative fluorescent lamps can be incorporated up to a maximum of three.



Low temperature testing

Flexing tests are sometimes required to be carried out at low temperatures. This determines the suitability of materials being tested to flex at temperatures below 0°C. SATRA provides a range of these machines and uses a low temperature cabinet specifically designed to suit the test.

The SATRA low temperature cabinet ensures maximum operator safety by having the electrical control and drive systems outside the freezer area where moisture cannot impair electrical safety. The control system incorporates a digital temperature controller which can be set to achieve the desired temperature from ambient down to -20°C, plus a counter to indicate the number of flexes carried out. The counter can be preset to stop the drive mechanism when completed.

STM 101F SATRA vamp flexer

This is a 16-station version of the SATRA vamp flexer. The stations are located inside the freezer area to allow simple loading of test specimens and easy/frequent inspections without having to stop the machine.

This is a SATRA preferred test as it replicates the creases formed in the upper (vamp) during walking and gives a more realistic indication of premature failure of the material similar to that experienced in normal wear.

For further details about this test refer to model STM 601-12 (page 12).



STM 408F Bally vamp flexer

This is an alternative low temperature test to the SATRA vamp flex, frequently referred to as the Bally flex test, and is mentioned in some international standards. It is more severe than the vamp flex test and failure is usually indicated more quickly, however some types of failure are not revealed by the test.

The STM 408F is an eight-station version and is built into the low temperature cabinet referred to above.

For further details about this test refer to model STM 701 (page 12).



STM 477F Bally vamp flexer (12 station)

This machine is the same as the STM 408F but has 12 stations. It is normally specified when a higher volume of testing is demanded.

See STM 701 (page 12).

STM 141F Ross flexer

This low temperature version of the Ross flex test is built into the low temperature cabinet described above. It is used for the flex testing of sole unit samples to assess the effect of flexing under low temperature conditions. It has 12 stations for small samples but can also accommodate larger samples by adjusting the mechanism.

For further details about this test refer to STM 141 (page 11).



STM 612F SATRA/Bata belt sole flexing machine

(see page 11)

STM 465F SATRA Whole sole flexing machine

(see page 12)

STM 567 SATRA Endofoot

This machine has been developed to assess the thermal and sweat management performance of complete footwear by measuring thermal insulation, moisture absorption and breathability properties, tested in conjunction with hose.

The test takes into consideration the effect of the sole, upper and lining, in addition to features such as seams and different types of hosiery.

The SATRA Endofoot can be utilised to help set comfort benchmarks and can be used for comparative testing of footwear components, for example, to assess experimental materials.

Data from the SATRA Endofoot equipment can be used to monitor and improve sweat management and thermal properties in all types of footwear – sports, performance, outdoor and industrial, as well as everyday dress shoes.

In operation the SATRA Endofoot uses a moulded foot form which incorporates electrical heating elements and water supply pipes that distribute 'sweat' (water) to the surface of the foot.

The foot is first fitted with a standard reference sock and then the test footwear. After a warming-up period to reach equilibrium, a realistic warm and humid environment is created which replicates that to be found inside a real shoe in wear.

The dressed foot is then subjected to a calibrated flow of air over its surface to replicate movement through the air when walking, (which helps to dissipate any moisture transmitted to the surface of the shoe).

In addition to moisture management tests, the test equipment can be used to conduct a cold rating test to determine the thermal properties (insulation) of footwear. Footwear comfort can then be assessed against guidelines for an external temperature and activities level.

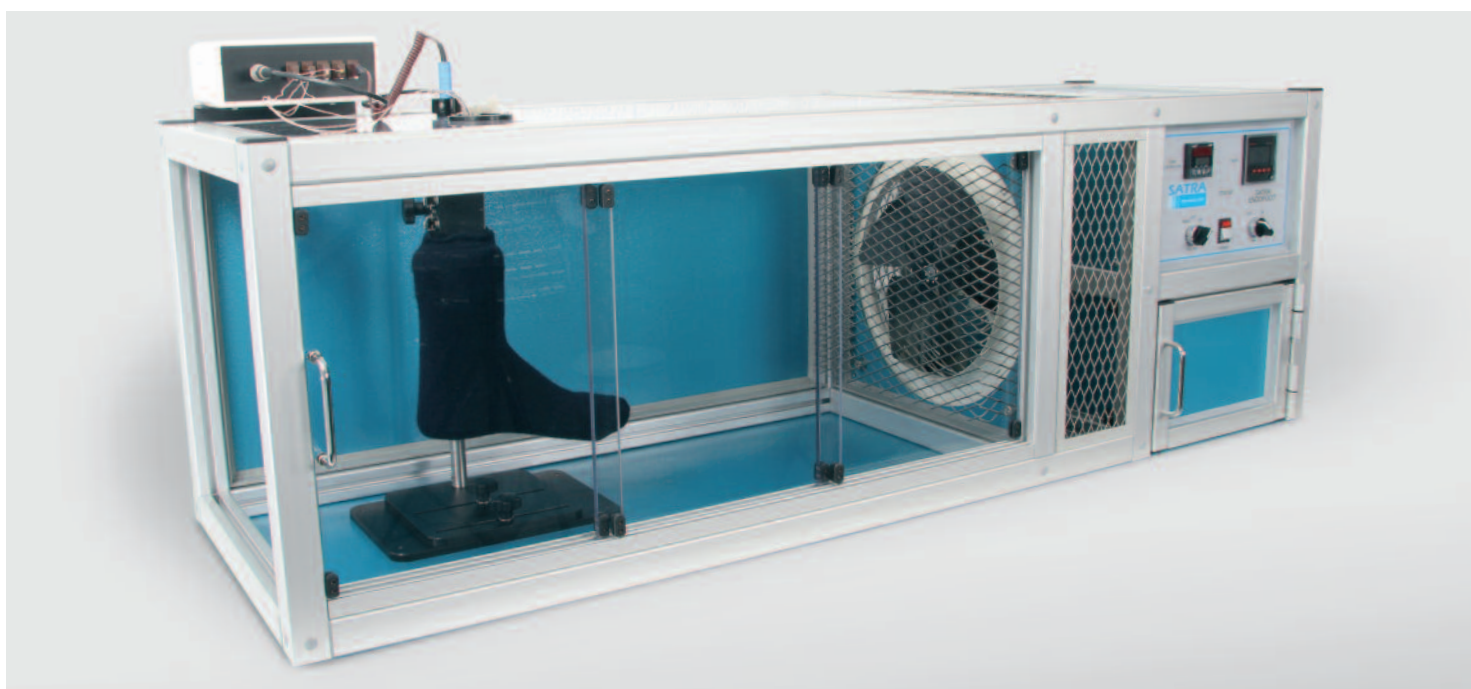

STM 524 Molten metal splash tester

Protective products often need to protect against the effects of impact from molten metal droplets. Safety standards, such as ISO 11611 and EN ISO 20349, have been developed to assess garments worn by personnel carrying out welding and cutting operations, against these effects.

Assessment of products being subjected to small quantities of molten metal – typical of that produced during welding – is carried out using a rig incorporating an oxyacetylene torch to project molten metal drops onto a vertically-oriented test specimen as detailed in EN 348.

A welding rod is fed automatically to the torch for continuous melting and the behaviour of materials is characterised by the number of molten drops sufficient to cause a 40°C temperature rise behind the specimen. The ability of the drops to ‘run off’ the material, rather than stick, is critical to good performance.

Although this test is suitable for testing welders’ clothing, gloves and footwear, it is not intended to simulate all the conditions in which splashes of molten metal may come into contact with protective materials.

As a standard test, it gives an indication of material performance and is generally used with other tests to provide a more complete picture of suitability for use.



Ozone chambers

HTE 703/903 Ozone test chambers

SATRA ozone testing technology has evolved as a result of more than 30 years of experience. State-of-the-art technology and construction techniques have been combined with expertise to produce a reliable, accurate, fully automated, labour and cost-saving unit which is truly environmentally safe.

An integral closed loop air-ozone system ensures that hazardous ozone gas is contained internally – eliminating the need to provide additional external venting and filtering of the spent gases.

The heavy duty aluminium exposure chamber has an anti-corrosive interior and is complete with racking system to accept sample-mounting apparatus. A range of static and dynamic sample holders to international standards is available. Access is via a double-glazed, airtight and safety interlocked door. Entry to the test area is prevented until the interior environment reverts to safe ambient levels. Exterior lighting can be excluded from the test area via a shade, while the interior can be lit by the integral test inspection lamp.

Controls and digital displays are logically laid out on a control panel and reflect the simplicity of operation required to set up a test routine. The only requirement is to set the ozone concentration, temperature, airflow, relative humidity (model 903 chamber only), test start and finish time.

The ozone concentration is variable from 25-500 parts per hundred million (pphm) – 25-2,000pphm option – and is automatically controlled and monitored. The set concentration and monitored concentration are digitally displayed, with the monitored concentration simultaneously output to PC (via Calcomms graphical software).

Ozone delivery accuracy of ± 5 per cent nominal full scale delivery (FSD) or better, typically ± 2 pphm in 50pphm, measured under stable absorption conditions. Typical recovery times after sample insertion: achieves 10 per cent of set value within 15 minutes.

Ozone generation is via UV ozone lamps with a maximum ozone generated output of 200pphm at 250 litres/min, and there is a high ozone option of 2,000pphm. The ozonised air flow of 40-440 litres/min is infinitely variable, allowing a maximum of three air changes per minute and an effective velocity of 3.3-33.3mm/sec. The internal circulation fan can be switched on to give 600mm/sec (2 feet/sec) according to ASTM D 1149. Ozone concentration measurement accuracy is ± 2 pphm. Control accuracy is 4 per cent of set point (± 2 pphm at 50pphm).

The test timer provides digital programming of up to seven days, with test start and test stop.

HTE 703

Temperature range options for model 703: 0-70°C.* 10-70°C. (Ambient + 5)°C-70°C.

*The testing of rubber at low temperatures down to 0°C is well documented, and conclusions from experiments undertaken using SATRA test chambers, which are capable of achieving such low temperatures, may have an important bearing on the future development of ozone test methods.

Temperature control accuracy: ± 1 °C at 40°C and ± 2 °C at 70°C. Typical temperature and ozone recovery period following sample insertion is < 10 per cent of set point after 15 minutes and 4 per cent after 30 minutes (cold start times will vary).

Electrical supply 220-240V/single phase/50-60Hz rated at 1kVA system, unaffected by variations of 10 per cent from normal.

HTE 903

Temperature range for model 903: 0-70°C. All ranges are automatically controlled by a solid state digital proportional controller, temperature digitally displayed and simultaneously output to a PC (via Calcomms graphical software).

Relative humidity (RH) control for model 903: Range 50 per cent to 80 per cent RH over exposure chamber temperature range of 23-40°C. Control accuracy of ± 5 per cent RH is achieved at constant temperature.

Water supply: Maximum temperature 15°C. Minimum pressure 2 bar. Maximum flow required 80 litres/hour. In areas of hard water, a de-calcinator should be used, and where a maximum water temperature of 15°C cannot be maintained, a recirculation chiller system should be employed.

Electrical supply 220-240V/single phase/50-60Hz rated at 3kVA system unaffected by variations of 10 per cent from normal.



STM 175 SATRA permeability and absorption test

This is a preferred SATRA test and unlike many other methods it attempts to simulate the environment within a shoe, that is 100% relative humidity at foot temperature. As well as measuring the amount of moisture transmitted through the material, the quantity of moisture absorbed by the upper can also be determined. This is important because although some materials may be impermeable, the ability to absorb moisture means that the foot will feel dry to the wearer. The moisture can desorb from the material by evaporation once the shoe is off the foot, for example, overnight.

An assembly of discs of outer material, lining (if used in the footwear) and a standard hose (sock) fabric is clamped across the top of a plastic pot containing distilled water. The water inside the pot is maintained at a temperature of 32°C by resting the pot in a temperature-controlled water bath. The atmosphere outside the pot is maintained by carrying out the test in a conditioned room and maintaining a flow of air across the top of the pot at a speed equivalent to a brisk walking pace. If the outer is permeable, water vapour passes through the cotton hose and the test material in the same way that perspiration would in a shoe.

The permeability of the material is determined by measuring the weight loss of the assembly at intervals throughout a six-hour period. Care is needed during the test to avoid splashing the reverse of the test sample with the water inside the pot and to ensure that the outer surface of the test pot is thoroughly dried after it is removed from the water bath for weighing. The absorption of the upper material, lining and the standard cotton hose are measured by weighing each disc at the start and end of test.



STM 473 Water vapour permeability

This device determines the amount of water vapour a material will transmit through its structure in a specified time. The test is mainly applicable to leathers and textiles used in footwear uppers and clothing where it gives a measure of the ability to remove perspiration from the surface of the wearer's skin.

The SATRA machine has six separate test stations on a rotary table and each one has a sample holder. Silica gel desiccant is placed in the holder and the test material is placed over the neck of the holder and secured by a screw top. After weighing each holder, complete with silica gel and sample material, the holders are placed and locked into the rotary mechanism. After 7-8 hours the complete holder is weighed again and the gain is used to determine the degree of permeability. It is essential that the entire operation is carried out in a conditioned atmosphere.

In addition to the standard equipment supplied with the STM 473, there is a built-in timer to record the number of hours that testing has been carried out.



STD 478 Water vapour absorption

The STD 478 water vapour absorption test apparatus measures a material's affinity to absorb water vapour. A test specimen is clamped between the open end of a test pot (containing a specified volume of water) and an impermeable seal. The pot is then stored at a specified temperature for a set time, after which the change in mass of the specimen is determined.

The STD 478 test apparatus consists of six test pots each having an internal diameter of 35mm and a volume of 100cm³, a removable lid which can be securely clamped over the open end of the pot and an impermeable seal held over the end of the pot by the lid.

In addition to the STD 478 apparatus, a laboratory balance and a stopwatch are necessary to determine water vapour absorption (available from SATRA).



Pinch and grip

STD 620 / STD 621 Glove pinch and grip tests

It has long been recognised that good glove grip is an important consideration for glove users, satisfactory performance and safety can be compromised by gloves with poor grip characteristics.

Historically, glove standards have been primarily aimed at the protective properties of the gloves or at basic dexterity testing. These two new machines are designed to fill this gap in the testing protocol and have been designed with input from within the glove industry.

The STD 620 pinch tester is designed to test performance of the finger and thumb 'pinch grip' element of the gloves, while the STD 621 grip tester is designed to test the performance of the whole hand grip. Both machines utilise load cells to record force data, and both machines are suitable for testing a wide range of gloves from fine textile and latex type products up to heavy duty industrial gloves. Testing can be undertaken on both clean and contaminated gloves and by combining the two different test methods an overall result for whole glove grip can be obtained.



STD 174 Break/pipiness scale

This is a widely-used reference scale for measuring the wrinkling of the grain of leather or the top surface of a synthetic material when folded inwards to a standard curvature

It consists of a graded selection of replicas of leather numbered one to eight with different amounts of pipiness and a mandrel for bending the sample to the same radius as the scale.

By using the numbered scale, a more objective evaluation can be made of the pipiness of a material.



Plastimeter

STD 449 Low profile plastimeter

The plastimeter is the standard SATRA test method for assessing the setting properties of leather. It is also used to test new synthetic upper materials and check the performance of heat setting machines by using a sample of material of known heat setting properties.

A disc of material to be tested is cemented to a brass ring and then placed in the plastimeter's clamping head. It is then deformed by forcing into it a non-metallic dome. This simulates lasting and is controlled by measuring the height of the formed dome of material with a micrometer. The deformation gives an area increase of around 15%.

While it is in the strained position, the dome plastimeter containing the sample is passed through the heat setting machine. After treatment, the dome is removed and the cap height of the dome, shaped in the material, is measured at various times. From this, the dome area is calculated and the proportion of the area increase retained is the 'plasticity' or 'set' of the material.



Resilience

STD 645 Resilience tester

The EPH-50 is a sturdy bench-mounted instrument designed to meet the requirements of the rubber industry.

Rebound resilience (elasticity) facilitates a simple method of measuring damping properties and is commonly used in conjunction with hardness testing for basic quality control.

The sample is located against a polished anvil and secured by spring clips. Adjustment can be made to accommodate differences in sample thickness. The pendulum is released from a horizontal position and strikes the sample at a vertical point. Its rebound height is displayed digitally as a percentage of its distance from the horizontal start position.



STM 643B / STM 421 Rub fastness tester

These machines are designed to carry out a rub fastness test on the surface of leather to determine the amount of 'marring' of the leather surface or the finish and to assess the amount of colour transfer from the sample to the rubbing pad.

The test can be carried out under dry or wet conditions by using a dry rubbing pad – or pre-wetting the rubbing pad in distilled water or a sweat solution prior to testing. The same machine can also be used to assess the abrasion resistance of insole boards. This test is covered by VESLIC – C4500 and IUP 450.

The testing machines are suitable for a wide range of tests that require a 'to and fro' movement on a material surface. The rubbing element, number of cycles, load and temperature can be adjusted to suit the test material requirements.

There are two models: a single (STM 421) and a two-station (STM 643B) machine. The latter also has the benefit of having one station heated for ironing tests. This test is used to determine the reaction of the leather surface to the application of heat and pressure particularly when experienced during 'ironing' but also when associated with the normal lasting process. Thermoplastic-based finishes are particularly susceptible to damage through ironing. The ironing characteristics of the leather can be influenced by the addition of agents in the finish which help them to achieve a leather surface favourable to ironing. A metal foot is provided with the machine to facilitate the ironing process. This test is covered by VESLIC – C4580.

The abrasion effect of soling materials on upper materials can also be tested on this equipment. Using a small profiled rubber pad in place of the felt pad, samples can be tested for this effect. Abrasion of the upper by the soling material can be caused in normal wear particularly when wearers cross their legs and the sole of one foot rests on the upper of the other foot. This test is covered by VESLIC – C4505.

The ability to pre-tension the test sample is a feature of both models. This is particularly useful when testing stretchy leathers and is a requirement of the abrasion test under C4580.

Operation is simple. The sample is placed on the test surface and clamped using the clamps provided. Pre-tensioning can be effected by adjustment of the knob or screw in conjunction with the percentage scale engraved on the testing table. A pre-determining counter is fitted to the machine, causing it to stop when the pre-determined count is reached. The square felt pad (STM 421P) is inserted in the machined holder on the end of the rubbing head which is then lowered to the surface of the test sample and the machine switched on. The material surface and the rubbing pad are inspected visually, in the case of colour transfer, the wool-felt rubbing pad is evaluated using the grey scale provided with each machine.

An initial supply of wool-felt pads is included with each machine.

The STM 643B is the only equipment approved and promoted by VESLIC.



STM 643B



STM 421

STM 461 Circular rub fastness tester

This machine determines the fastness of the finish of a leather upper, leather lining, synthetic upper or lining and fibreboard. Rubbing can be carried out in dry or wet conditions. The latter can be water, solvents in shoe polish, or toe puff (box toe) solvents applied to the back of the material.

Fastness can be judged by the effect on the sample material or the transfer of colour to the rubbing pad. The change in appearance of the finish and the colour transferred to the rubbing pad is assessed by reference to a standard scale.

The machines can also be used for testing the rub/abrasion resistance of inks on printed films under dry or oily conditions.

The machine has a rotating head holding a circular felt pad under a load of either 0.73kg or 2.5kg as required. The rotating head and felt pad can be raised from the sample surface by means of a hand lever or automatically in the case of STM 462, allowing the test specimen to be examined during the course of the test. The counter operates only when the felt pad is in contact with the test specimen. It is a pre-determined counter which can be set to stop the machine when the preset count has been reached.



STM 462 Circular rub fastness tester

This machine has all the attributes of the STM 461 but with two additional features.

1. An automatic feature to raise and lower the felt pad to and from the specimen surface while the test is in progress: this prevents overheating of the specimen as a result of abrasion between the felt pad and the test specimen which can adversely affect results.
2. An air blower which directs an adjustable stream of cooling air onto the surface of the specimen to prevent overheating of the sample during the test.

Shock absorption

STM 479 Dynamic shock absorption

Although the human body can be effective in absorbing shock when jumping, running or walking, injuries can still occur through impact loading to the foot. Such injuries could be mitigated by the provision of shock absorbing capabilities within footwear. For everyday footwear, shock absorbance within the heel construction can be a benefit to the wearer. Sports footwear and other high performance footwear, including for military use, pose additional challenges for managing impact loading.

For all these types of footwear, being able to conduct a controlled, mechanised test with repeatable results to determine shock absorption capabilities provides a valuable contribution to product design, verification or assurance of consistent quality.

The STM 479 allows a dynamic shock absorption test to be carried out on footwear, cushion insoles or construction materials and provides quantifiable test results. The machine operates by allowing a known mass to fall onto the sample from a defined height. By use of an accelerometer and displacement transducer, a value for the peak deceleration (g factor) for the falling mass is determined. In addition, the test allows an assessment to be made of the energy return on rebound. This information is displayed on a computer – not supplied – and graphical displays can be printed. This machine is suited for combination testing with SATRA STM 512 repeated compression tester.

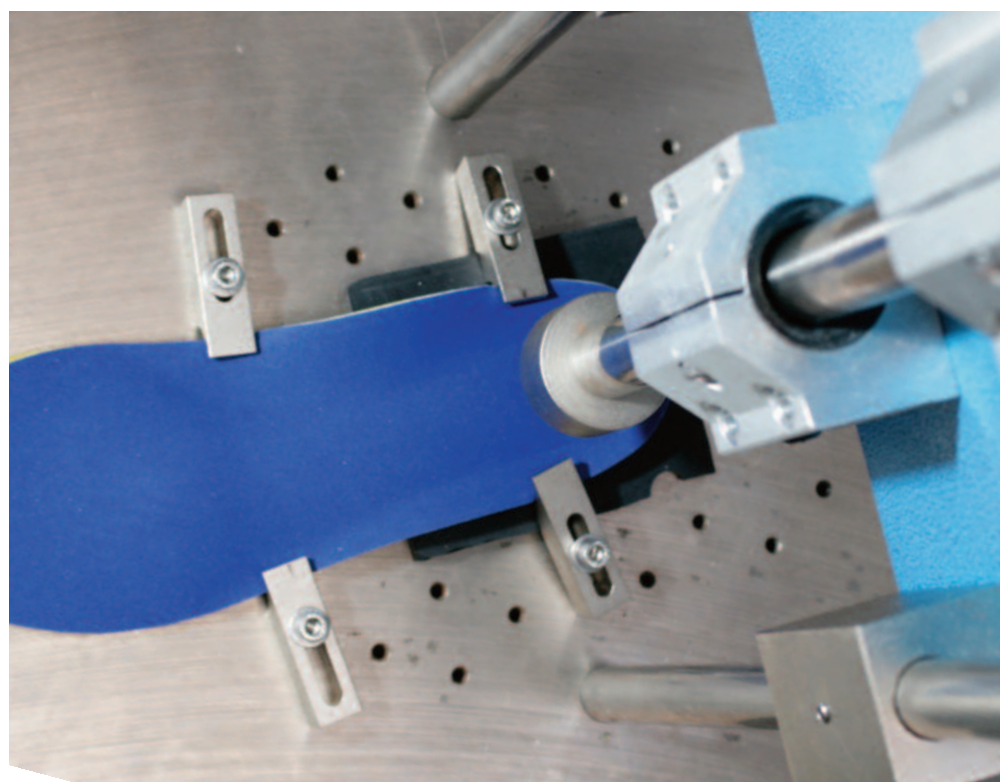

STM 603 Slip resistance tester

The SATRA slip resistance tester has been developed following extensive biomechanical studies. A normal walking step commences with heel strike and ends as the toe is lifted from the ground. Slip is most likely to occur shortly after heel strike and just before toe lift when half body weight is being applied. The SATRA equipment recreates these conditions and measures the slip resistance between the sole of the footwear and the floor surface. The equipment's unique design allows it to measure the slip resistance of solings against standard flooring materials, or flooring materials against standard solings. Each machine is supplied with a standard, calibrated floor surface. Additional surfaces are available and almost any floor surface, which can be attached to the machine, can be used.

Determining friction or slip resistance is a complex process requiring careful and accurate monitoring of numerous parameters in a relatively short time. A computer, housed in the control console, manages data acquisition and provides a graphic representation of the test data and coefficient of friction (CoF) for each sample tested. This is achieved through constant, close control of forces and motion speed via a variable-speed motor and unique circuitry design. Test results are displayed as a four line, captioned graph, representing vertical load, speed of table movement, horizontal load, and coefficient of friction.

Test standards place great importance on the timing and method of obtaining results. The unique SATRA software controls the machine and manipulates data gathered during the test. It ensures accurate control of the entire procedure, strictly in accordance with the test standard parameters. Principal tests, SATRA TM144, EN ISO 13287 and ASTM F2913-11, are pre-set in the software included with the machine. Users may also add their own test standards. These settings can be saved and recalled for repeat testing. Test standards, including user-defined settings, can be selected from a drop-down list to simplify operation. Based on the user's selections, the machine is pre-set to the required speeds, delays, and point (snapshot) at which the CoF is calculated. To safeguard quality control, essential data must be entered before new tests can proceed. The operator's name, test standard, test surface and all other relative data are recorded.

A unique function of the SATRA software is its self-teach mode applied during testing. Vertical load is monitored during each test and adjusted for the following test if required, ensuring the vertical load is always correct.



STM 135 State of cure tester

This device is used for measuring variations in the degree of cure in moulded-on rubber soles throughout their thickness.

The test procedure is based on the fact that hardness varies in most rubbers, according to the state of vulcanisation.

The resistance to indentation, which is determined by the hardness of the rubber, is measured at several positions through the thickness of a sample taken from a defined position in the sole or heel. The sample rests on a vibrating plate and an indenter is lowered onto it. After 10 seconds, the dial gauge is set to zero and the indenter is loaded. After a further 15 seconds the depth of indentation is read from the dial gauge.

The readings of indentation depth are plotted against their position, relative to the inner and outer surfaces of the sole, and a curve indicating the cure of the sole is drawn. From this graph the amount of 'undercure' near the inner surface of the sole can be calculated.

The equipment consists of a dial gauge fitted with a 60° conical end to the plunger and a removable 500g weight, all mounted on an electrically-vibrated base plate.



Stiffness

STM 507 Dynamic footwear stiffness tester

In bio-mechanical trials organised by SATRA, running in a stiff shoe was found to involve more muscle activity in the lower leg and 5 per cent greater energy usage than in a flexible shoe. Longitudinal flexibility, therefore, is a desirable property for sports shoes and especially running shoes. Flexibility is also desirable in children's footwear, where undue strain should not be placed upon the still-growing and developing foot.

In operation, the footwear is flexed about a defined line drawn across the forepart, the bending moment required to flex the footwear and the maximum angle achieved are recorded and used to calculate the SATRA stiffness index.

Torsional stiffness is a measure of the resistance to twisting of footwear about its longitudinal axis. The footwear is clamped in the toe area, forces are applied through the heel clamp such that the heel and backpart is twisted first inwards and then outwards up to a maximum angle. The torque required to achieve the twist is used to calculate the torsional stiffness values.

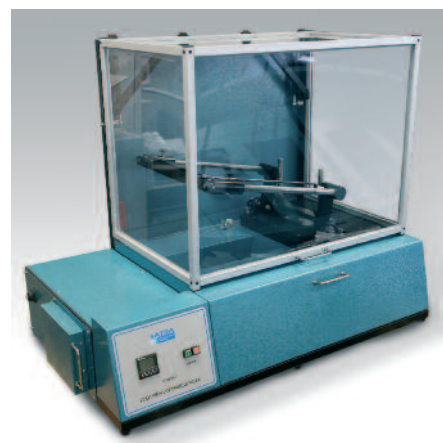

Tensile testing

STD 172 Simple tensile tester

This general purpose machine has been designed to measure the strength and stretch of a variety of shoe materials with an accuracy sufficient for many requirements of the shoe manufacturers. It is easy to use and the load and extension values can be easily read. The instrument is suitable for testing most shoe materials if the load does not need to exceed 150lb or 68kg and the extension 100%.

The machine can also be used for the Baumann tear test and jaws STD 172ST, to suit this test, are illustrated in the photograph right. These jaws need to be ordered separately.

In use, a strip of the material being tested is clamped between two jaws, initially four inches (10cm) apart, which are separated by a hand drive to apply increasing tension. One jaw is fixed to a cantilever beam. The deflection of the end of the beam is proportional to the applied load and is measured by a dial gauge calibrated to give the load directly. The dial gauge is fitted with a maximum-reading device to make it easy to measure breaking loads. The second jaw moves over a scale which gives the extension as a percentage.

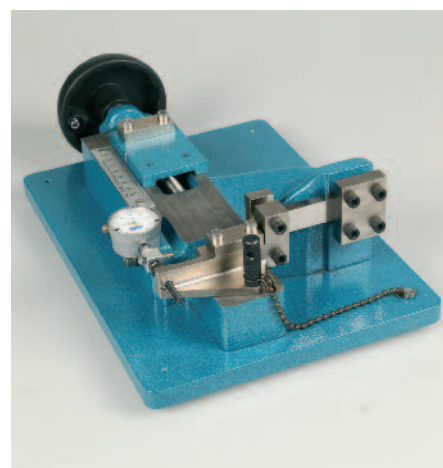

Tensile testing

STM 566 / STM 766 Tensile testers

SATRA's tensile testers are robust twin column machines with reliable mechanical attributes and incorporate digital software control. The machines deliver precision performance through high efficiency pre-loaded ball screws, high resolution load cells and digital AC servo drive. The machines operate in both tension and compression modes and provide up to 8 times overload capacity without damage to the loadcell.

The software provided runs from a computer (not supplied) and is user friendly with large display pages for inputting data.

This software allows the operator to load test methods required or to create specific requirements for individual tests. Displays and reports can be customised with for example, specific headings or company logos.

The STM 566 machine typically has a load capacity of 5kN or less whereas the STM 766 typically has a load capacity of 20kN. This higher capacity is particularly relevant for compression testing of, for example, safety toe caps.

Both machines occupy the same footprint and a range of test-specific jaws is available upon request from SATRA.

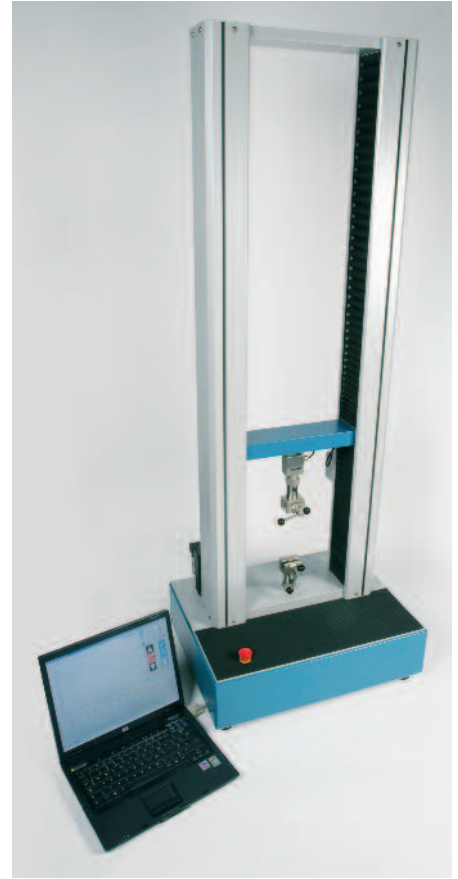

STM 566 Tensile testing machine accessories



STM 566SB

This specially shaped 'C' clamp is normally used in the peel strength testing of footwear sole to upper. It can also be used as a general purpose clamp.

Top clamp provided (used in conjunction with 566F or 566QR bottom clamp).

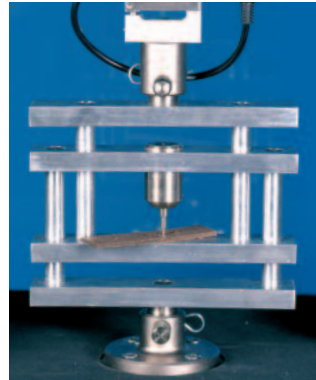

STM 566H

This attachment is used to determine the heel pin holding strength of footwear insole board, particularly in the seat region.

Supplied as a complete unit.



STM 566F

This is a versatile, standard, flat jaw, used for a variety of general purpose clamping.

Sold individually (normally a pair would be required).



STM 566TB

These SATRA thread bollards are used to determine the breaking load of threads and laces.

Supplied as a pair of jaws.

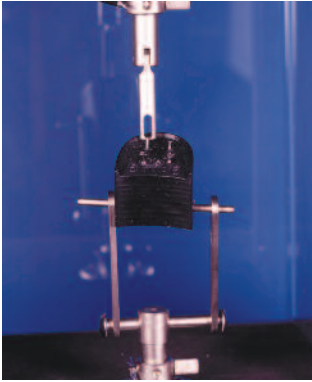

STM 566HP

This test was developed to assess the strength required to pull a nail from the heel of footwear. Supplied as a pair of jaws.

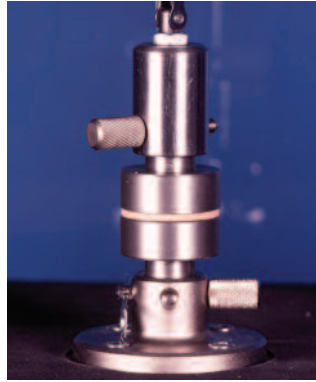

STM 566Z

The transverse through thickness tensile strength through thickness of sheet materials, usually called the 'Z tensile test', is measured using this device. Supplied as jaw set (top & bottom).



STM 566HA

This is used to measure the strength of attachment of heel to shoe. Bottom clamp provided (used in conjunction with an STM 566F top clamp).



STM 566AF

This is used for testing the strength of adhesion of the finish or coating to the leather or synthetic material. It consists of a hook attached to one jaw and a sample holder to the other. Supplied as jaw set.

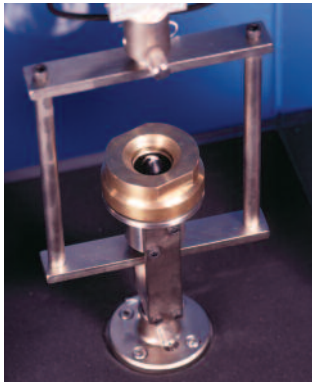

STM 566LH

With this attachment lastometer tests can be carried out to check the burst or crack strength. Supplied as a complete unit.



STM 566WT

Supplied as a pair, the top-line bollards are used to determine breaking force and extension at break of whole shoe top-lines.

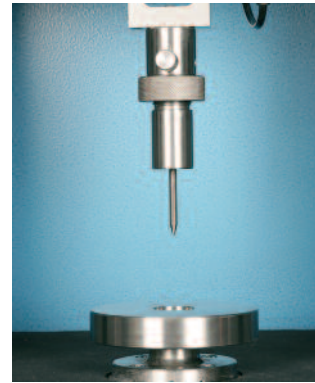

STM 566NP1

This tests a whole sole unit, complete with protective midsole, for nail penetration. Supplied as jaw set (top and bottom).



STM 566NP2

This tests the protective midsole as a separate unit for nail penetration. Supplied as jaw set (top and bottom).

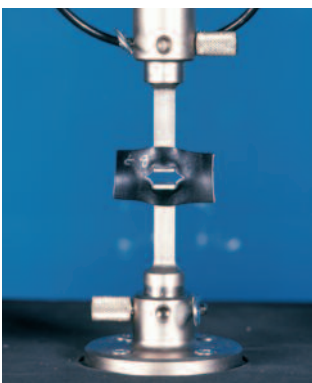

STM 566ST

Often called the 'Baumann tear test', this is the industry standard for testing the tear strength of leather. Supplied as a pair of jaws.

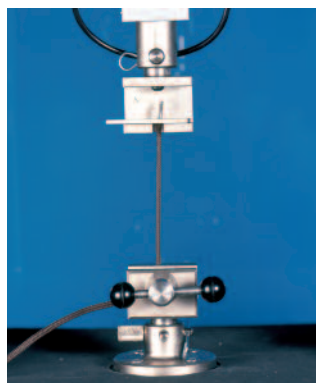

STM 566LT

This is used to assess the attachment strength of the shoelace tag to the lace. Top clamp provided (used in conjunction with an STM 566F bottom clamp).

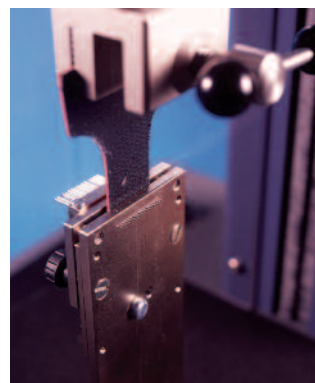

STM 566NT

Normally called the 'needle tear test', this device allows the sample material to be clamped and a series of needles pushed through the material. Bottom clamp provided (used in conjunction with an STM 566F top clamp).



STM 566QR

This is a unique self locking jaw with a quick release action, which can be used as a general purpose clamp for many duties. Sold individually (normally a pair would be required).

Thermal resistance

STM 511 Sweating guarded hotplate

The sweating guarded hotplate (often referred to as the 'skin model') is a device for measuring the thermal resistance or water vapour resistance of a material or composite. The test is designed to simulate the transfer processes of heat and moisture through materials next to the human skin and to measure the rate of transfer of heat or moisture in such processes. It is, therefore, particularly relevant for assessing the ability of clothing and footwear materials to transmit moisture or heat, primarily under steady-state ambient conditions.

The test machine comprises an environmental cabinet, which allows the temperature and humidity to be closely controlled, into which is integrated the specific hardware required to conduct the tests. At the core of the machine is the measuring unit consisting of a porous metal plate attached to a conductive metal block fitted with heating elements. Also contained within the block is a water reservoir fed by a closely-controlled water supply which keeps the water level up to the underside of the porous plate.

During a test, the test material is placed on top of the porous plate. Surrounding the measuring unit is a guard ring which is set level with the top of the porous plate or can be raised to be flush with the top of the test material in the case of a thick foam or composite material, for example. A support table is set to the outside of the guard ring and flush with the top of the ring. A crossflow fan provides a controlled rate of airflow through a polycarbonate duct over the test specimen during the test. The airspeed is monitored using an installed sensor.

The test method detailed in EN 31092/ISO 11092, for example, is a steady-state test suitable for the measurement of thermal resistance and water vapour resistance of fabrics, films, coatings, foams and leather. It is currently the approved method for assessing the performance of breathable and insulating materials for a number of footwear specifications, particularly those used by the military. The test method also has applications in clothing, sleeping bags, upholstery and similar textile type products.

EN 31092/ISO 11092 specifies two test methods. One method is used for measuring water vapour resistance, which is the water vapour pressure difference between the two faces of the test sample divided by the resultant evaporative heat flux per unit area in the direction of the water vapour pressure gradient. This is called R_{et} and is expressed in square metres pascal per watt.

The other method measures thermal resistance, or R_{ct} , (expressed as square metres Kelvin per watt), which is defined as the temperature difference between the two faces of the test sample divided by the heat flow per unit area.



Thermal – Whole shoe

STM 567 SATRA Endofoot

This machine has been developed to assess the thermal performance of complete footwear by measuring thermal insulation. It also measures moisture absorption and breathability properties, and is tested in conjunction with hose.

Data from the SATRA Endofoot equipment can be used to monitor thermal properties in all types of footwear – sports, performance, outdoor and industrial, and everyday dress shoes. For a more detailed description, including photograph, see STM 567 on page 22.

STD 483/484/495 SATRA thickness gauge

SATRA manufactures a standard thickness gauge which can be adapted to meet most international standards.

The gauges are manufactured to close tolerances and can be used as quality control instruments to measure the thickness of a wide range of materials, including leather and textiles.

It is crucial that any thickness gauge applies a controlled pressure (kPa) to the material whose thickness is being measured. SATRA uses a deadweight system removing the uncertainty of other mechanical devices. This system ensures that the thickness is being measured under the same controlled conditions for each sample. The SATRA system ensures excellent repeatability of results. To measure the thickness of any sample, lift the deadweight by operating the lever and insert the material between the anvil and the presser foot. Lower the deadweight using the same lever.

STD 483 Thickness gauge for leather

STD 484 Thickness gauge for synthetic materials

STD 495 Thickness gauge for rubber



Toe puffs (box toes)

STD 153 Toe puff (box toe) and stiffener (counter) testing

Main properties

Traditionally, all the performance properties of toe puffs (box toes) and stiffeners (counters) have been related to hardness (dome strength) values. Hardness is still regarded as the main property since it will always be closely related to the footwear application. Most of the other properties need not be related to hardness.

All of the following tests listed that are applicable to toe puffs and stiffeners are SATRA test methods.

Dome forming

Preparation of dome-shaped test pieces from toe puff and stiffener materials for the measurement of area shape retention and dome strength.

With this method the material is brought into a mouldable condition in the same manner as used in practice. It is then shaped over a spherical dome under pressure using SATRA Ref: STD 153/D and STD 153/P.

The sample is allowed to cool under tension. The strength of the material is its ability to withstand collapse when formed into a three dimensional shape or dome. Thermoplastic materials are usually heated in a fan assisted oven at 95°C for eight minutes raising their temperature to 80°C. Solvent-activated materials are dipped in their appropriate solvent usually for one to two seconds. Fibreboard materials are held in a jet of steam at approximately 50°C for six minutes.

A minimum of 6 dome formers (STD 153D) are recommended to allow the testing of 6 samples at the same time.

Area shape retention

Measurement of the area shape retention of formed toe puff and stiffener materials.

When a toe puff and stiffener material is moulded to shape it increases in size. As soon as it is released from the mould some of the area increase is lost and the area loss continues in wear due to mechanical deformations and wetting. The greater the area loss, the poorer the shape and appearance. With stiffeners, the higher the shape retention the better and, after ten collapses, 80-90% is not uncommon.

The area shape retention is determined by measuring the height of the dome at various stages using SATRA Ref: STD 153/H and STD 153/HD.

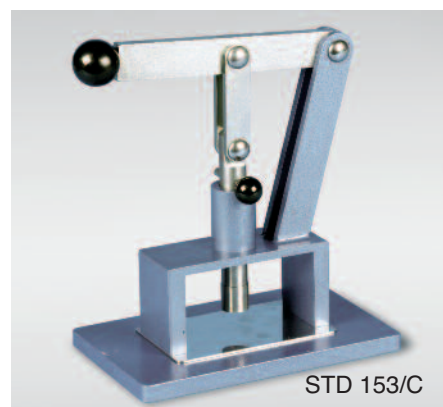
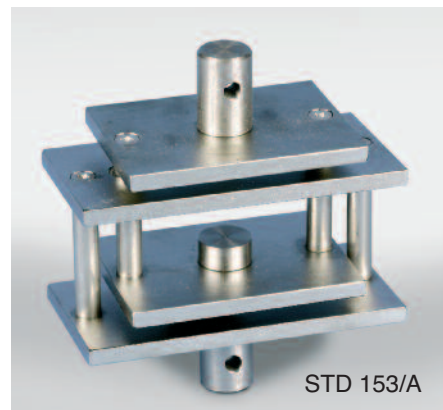

Continued over page

Toe puffs (box toes)

The area of the dome is directly proportional to the height and since the dome is initially formed to a standard height the area shape retention can be found. This test method is performed in tandem with SATRA TM83 (collapsing load).

As a result, initial shape retention and long term shape retention (ten collapses) can be assessed. The shape retention and collapsing load, are repeated on samples immersed in water to simulate the effect of moisture in wear.

Collapsing load

Measurement of the collapsing load of formed toe puff and stiffener materials.

This provides a procedure for measuring the strength of toe puff and stiffener materials in a way that corresponds to wear performance conditions. The top of the formed dome is compressed at a constant rate in a tensile testing machine SATRA Ref: STM 566 and STD 153/A – a cylindrical plunger with a level lower surface.

Initially, resistance to compression increases as the dome deforms until a maximum value is reached. After this the test piece collapses and the resistance to deformation falls. The maximum load is reported as the collapsing load: so initial hardness is the load required to produce an initial collapse of the formed dome. This is repeated utilising STD 153/C and, after nine additional collapses, the load to produce the tenth collapse can be determined in the same way as the initial load.

Toe puffs can range in hardness from 180N for military footwear to 10N for fashion shoes with soft upper materials. Toe puff materials require strength to resist the compressive forces due to fall-in. Even a properly heat-set leather upper may retain barely 70% of its original shape.

Resilience provides a measure of the resistance to the small repeated distortions that occur in wear – and the large distortions that are due to accidents or misuse. Most filmic materials have excellent resilience and logically the softest counters are required to have the highest resilience.



STD 153/H or
STD 153/HD



STD 153/P

Vacuum forming

Vacuum forming machines

These machines were designed to allow shoe manufacturers to form a model (shell) of a last. Designers could then draw on the plastic shell to produce new designs. These could then be shown to prospective customers to gauge opinion before committing the design to manufacture. It is also possible with careful cutting to flatten the shell to create the first pattern prior to cutting the first uppers.

The same machines are also ideal for use in schools where craft, design and technology are taught. The visual impact that the student witnesses as each vacuum form is produced is an important stage in the learning process.

STM 329 Vacuum former

Locate one of the sample plastics sheets provided with each machine, clamp it into place and swing the entire clamp up towards the heater box. Watch the plastic soften, judge when to start forming and with the form simply placed on the moulding frame drape the heated/softened plastic sheet over the form and start pumping out the air to create a vacuum.

Forms (moulds) are easy to produce from a variety of materials, including plaster of Paris, wood or any other reasonably rigid material.

A standard range of moulds and accessories is available and full instructions on how to use the machine are provided.

The STM 329 version, pictured, is fitted with a hand pump which is easy to operate.



STM 330 Motorised vacuum former

This motorised version with a mains-powered vacuum pump is at the top of the range and is a well-trying and proven concept.

Forms (moulds) are easy to produce from a variety of materials, including plaster of Paris, wood or any other reasonably rigid material.

A standard range of moulds and accessories is available and full instructions on how to use the machine are provided.



Water resistance

STM 505 Dynamic footwear water resistance tester

This test machine is rapidly becoming an internationally-accepted standard for laboratory testing of footwear. The results for this test closely follow the standard trough test where the wearer walks in water to assess the resistance of footwear to ingress. The SATRA dynamic water penetration tester is a laboratory test which flexes the footwear in water contained in a clear polycarbonate tank. This twin-station machine comprises two separate water tanks and two independent flexing mechanisms.

Each station has an independently-controlled air cylinder to raise and lower the footwear in and out of the tank. A pre-determined counter enables the machine to be left unattended. When the pre-set count is reached the footwear will rise out of the water.

This equipment is used on a daily basis in SATRA's state-of-the-art laboratories and is proving to be the most reliable automated test for water resistance testing. It is performed on the whole shoe and tests all aspects of the footwear, including the materials, construction, seams and sole bond. The same machine can also be used for testing the effect of protective coatings applied to footwear.



STM 606D Water resistance tester for upper leather (Maeser type)

This equipment is designed to test the water resistance of upper leathers (and upper leather substitutes) under conditions of flexing similar to those in the forepart of a shoe during walking.

One clamp is moved/rotated repeatedly through an angle of 32° to form creases in the specimen similar to those produced during walking. A pre-determined totalising counter is fitted.

Rectangular test pieces are folded into a vee shape and held in watertight clamps. A tank containing water is then raised so that the test piece is surrounded by water. One clamp is then moved up and down repeatedly by a driven crank linkage, forming creases in the leather similar to those produced in the shoe vamp. A resettable counter is fitted and the number of flexes before water penetration is observed and recorded as the test result.

The system incorporates an individual counter for each station, plus visual and audible alarms. There is a three-position switch to select one of three sensitivities (10K, 30K and 50K ohms). The individual station counter stops recording when water penetration is first detected and switches on the alarm while the remaining stations continue the test. The device can be retro-fitted to existing equipment. The machine accommodates four test pieces.

See also STM 184 and STM 184H (page 12).



Water resistance

STM 703 Bally penetrometer STD 704 Bally stiffness meter

This four-station machine is the internationally accepted method for measuring the dynamic water resistance of leathers and synthetic leathers. Its unique action ensures that each test piece is assessed under the conditions relevant to the stiffness of the specimen.

The specimens are wrapped around the mandrels provided and held in place by clamps. Specimens and mandrels are mounted utilising the dovetail arrangement forming part of the mandrel and the corresponding dovetail on the machine. The amount of dynamic movement (amplitude) is adjustable according to the stiffness of the material, which should first be measured on the SATRA Bally stiffness meter STM 704. A tray can be raised to allow water to contact the finish side of the specimens.

A significant feature of the SATRA Bally penetrometer is the electronic water detection system which removes the need for constant operator attendance during testing. This feature also includes a counter and alarm for each of the four stations. Water detection relies on a resistance being reached in the electronic circuit. Copper mesh is placed in each specimen and a probe forms the link between the electronic circuit and mesh. When water penetrates the specimen the resistance changes and automatically stops the station counter and sounds the alarm. Testing continues on the other stations until water penetration is detected at all stations when the machine stops.

These features are unique to the official SATRA Bally penetrometer:

- Adjustable amplitude
- Adjustable electronic water detection system
- Specimen stiffness measurement.

Other features:

- Electronic counter per station
- Master electronic counter
- Specified in many international and European standards
- Mechanically reliable.

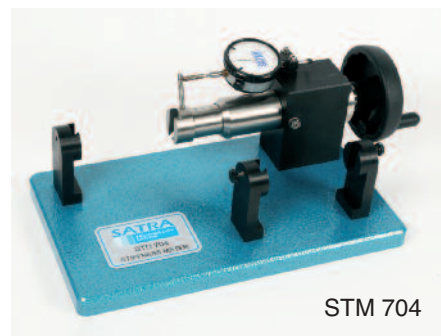

STM 706 Bally permeometer

This machine assesses the water resistance of heavy leathers, particularly sole leathers. It is the only internationally accepted method for determining this property.

STM 706 uses a dynamic motion during the test closely corresponding to the conditions experienced during wear. The test piece is repeatedly bent and laid flat again under load, as a shoe sole during walking, while in contact with water on one of its sides. The penetration of moisture through the test piece is automatically detected and reported by an acoustic or visual signal.

It is possible to determine the following values using this unique piece of SATRA Bally test equipment:

- The time taken for the water to pass through the test piece
- The quantity of water absorbed by the test piece within different time intervals
- The quantity of water passing through the test piece and given up on to an absorbent layer within a defined time limit (permeability).



Zips

STM 590 Zip tester

This machine tests zip (slide) fasteners and complies with SATRA Test Method 50:1992, Method 1.

It tests up to three fasteners simultaneously by repeatedly opening and closing them until either the fastener fails or the number of preset cycles is reached.

The zip fastener is held vertically between a lower fixed clamp and an upper loaded clamp. Horizontal loads are applied to the fastener by two horizontal clamps and load masses.



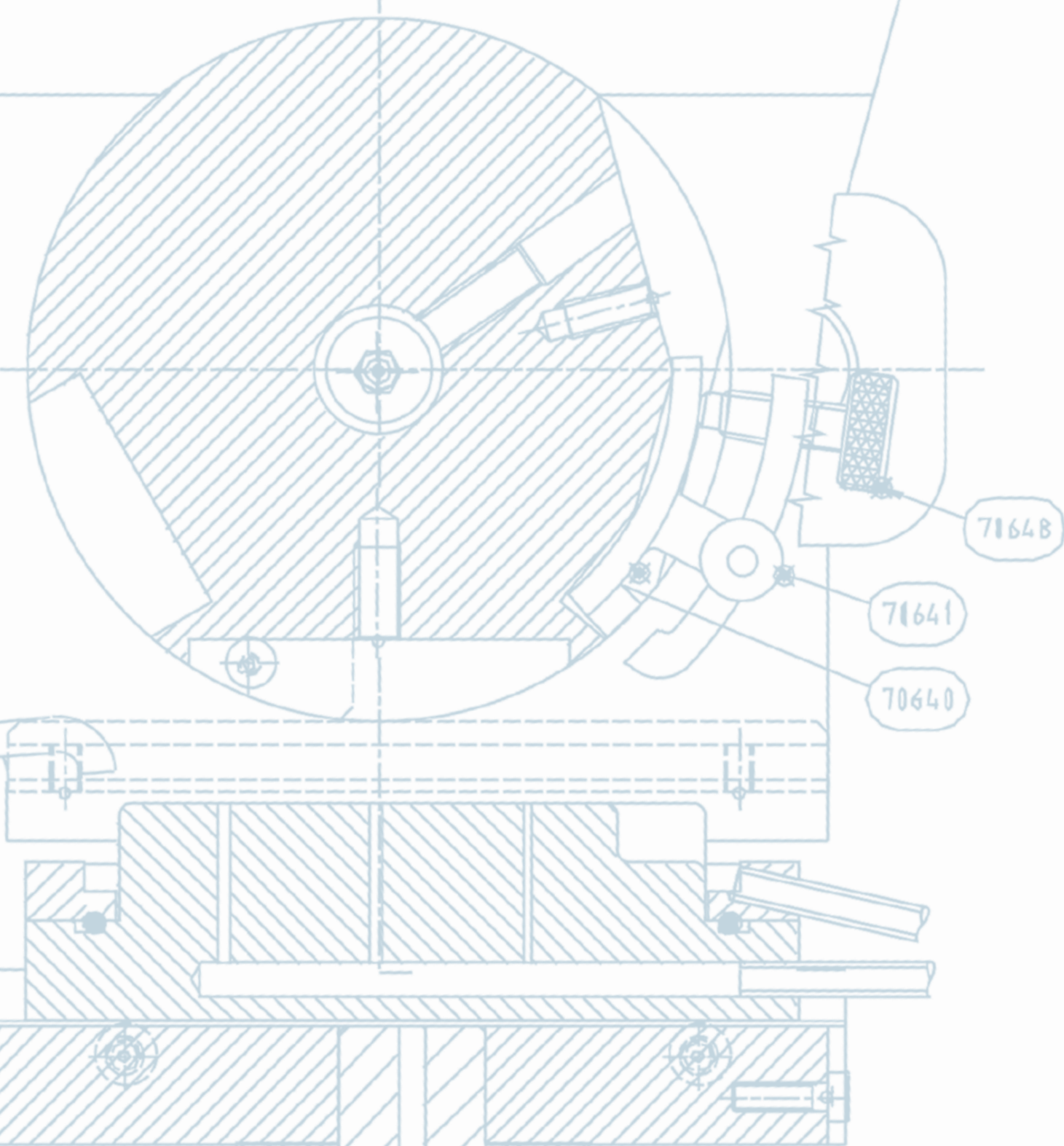

test.equipment@satra.co.uk



Wyndham Way, Telford Way, Kettering,
Northamptonshire, NN16 8SD, United Kingdom
Tel: +44 (0)1536 410000 Fax: +44 (0)1536 410626
email: info@satra.co.uk www.satra.co.uk

SATRA Ref: 0224183/2014